

REVIEW ACTIVITIES: ARMY-EL, MU  
USER ACTIVITIES: ARMY-GL

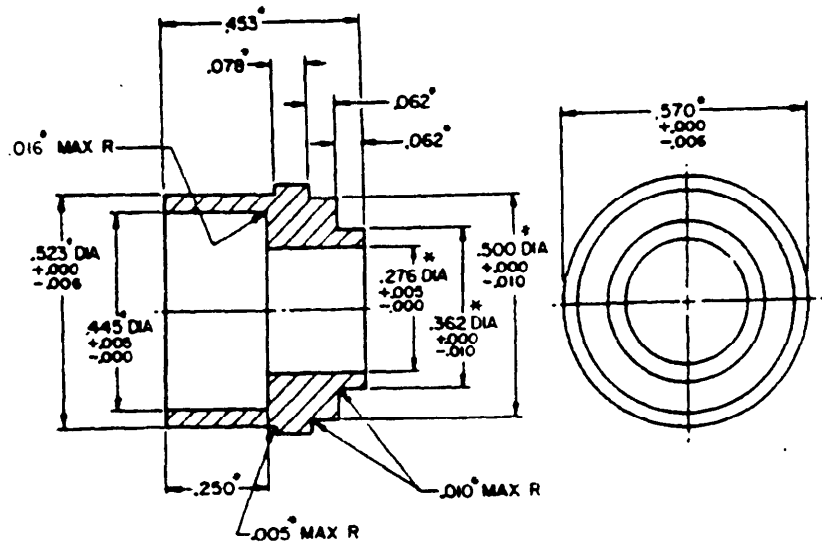

DIMENSIONS ARE IN INCHES

NOTES:

1. MATERIAL: BRASS, SPEC. QQ-B-626, COMP. 11 OR 22, TEMPER HALFHARD.
2. FINISH: CADMIUM PLATE, SPEC. QQ-P-416, TYPE II, CLASS 2.
3. UNLESS OTHERWISE SPECIFIED, DIMENSIONS ARE IN INCHES AND TOLERANCES ARE  $\pm .005$ .
4. SHEET 2 IS IDENTICAL WITH SHEET 1 EXCEPT THAT DIMENSIONS ARE IN MILLIMETERS.
5. REFERENCED DOCUMENTS SHALL BE OF THE ISSUE IN EFFECT ON DATE OF INVITATION FOR BIDS.

THIS IS A DESIGN STANDARD AND SHALL NOT BE USED AS A PART NUMBER.

"CERTAIN PROVISIONS (IDENTIFIED BY \*) OF THIS STANDARD ARE THE SUBJECT OF INTERNATIONAL STANDARDIZATION AGREEMENT NATO STANAG 4006. WHEN REVISION OR CANCELLATION OF THIS STANDARD IS PROPOSED WHICH WILL EFFECT OR VIOLATE THE INTERNATIONAL AGREEMENT CONCERNED, THE PREPARING ACTIVITY WILL TAKE APPROPRIATE RECONCILIATION ACTION THROUGH INTERNATIONAL STANDARDIZATION CHANNELS, INCLUDING DEPARTMENTAL STANDARDIZATION OFFICES, IF REQUIRED."

(A) ENTIRE STANDARD REVISED

"This military standard has been approved by the Department of Defense and is mandatory for use by all Departments and Agencies of the Department of Defense. Selection for all new engineering and design applications and for repetitive use shall be made from this document."

APPROVED 25 APRIL 1958 REVISED (A) 11 OCTOBER 1967

P. A. ARMY-AT Other Code NAVY-YD AF-85	INTERNATIONAL INTEREST	TITLE FERRULE, ELECTRICAL CONDUIT: SPARK PLUG CABLE (OTHER THAN AIRCRAFT)	MILITARY STANDARD MS 39018
PROCUREMENT SPECIFICATION NONE	SUPERSEDES	SHEET 1	OF 2

REVIEW ACTIVITIES: ARMY-EL, MU  
USER ACTIVITIES: ARMY-GI

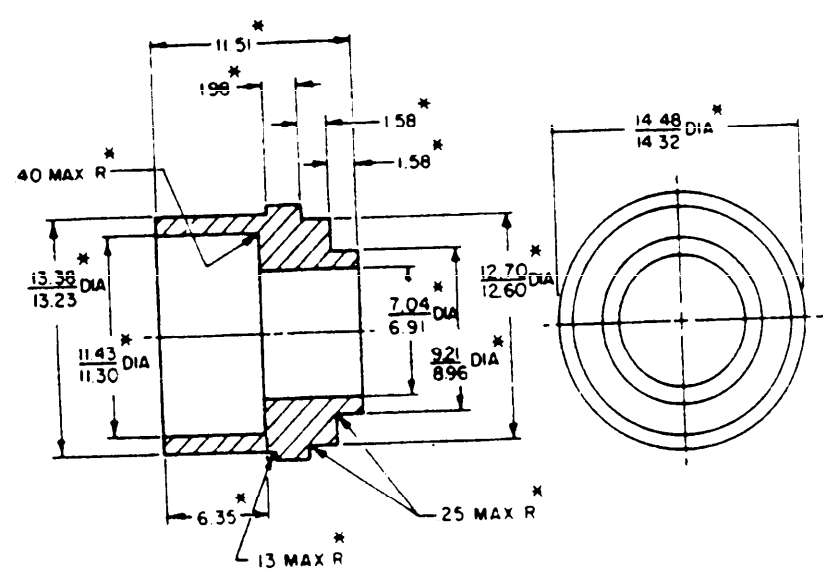

DIMENSIONS ARE IN MILLIMETERS

NOTES:

1. MATERIAL: BRASS, SPEC. QQ-B-626, COMP. 11 OR 22, TEMPER HALFHARD.
2. FINISH: CADMIUM PLATE, SPEC. QQ-P-416, TYPE 11, CLASS 2.
3. UNLESS OTHERWISE SPECIFIED, DIMENSIONS ARE IN MILLIMETERS, TOLERANCES ARE  $\pm 0.13$ .
4. SHEET 1 IS IDENTICAL WITH SHEET 2 EXCEPT THAT DIMENSIONS ARE IN INCHES.
5. REFERENCED DOCUMENTS SHALL BE OF THE ISSUE IN EFFECT ON DATE OF INVITATION FOR BIDS.

THIS IS A DESIGN STANDARD AND SHALL NOT BE USED AS A PART NUMBER.

"CERTAIN PROVISIONS (IDENTIFIED BY \*) OF THIS STANDARD ARE THE SUBJECT OF INTERNATIONAL STANDARDIZATION AGREEMENT NATO STANAG 4006. WHEN REVISION OR CANCELLATION OF THIS STANDARD IS PROPOSED WHICH WILL EFFECT OR VIOLATE THE INTERNATIONAL AGREEMENT CONCERNED, THE PREPARING ACTIVITY WILL TAKE APPROPRIATE RECONCILIATION ACTION THROUGH INTERNATIONAL STANDARDIZATION CHANNELS, INCLUDING DEPARTMENTAL STANDARDIZATION OFFICES, IF REQUIRED."

(A) ENTIRE STANDARD REVISED

"This military standard has been approved by the Department of Defense and is mandatory for use by all Departments and Agencies of the Department of Defense. Selection for all new engineering and design applications and for repetitive use shall be made from this document."

APPROVED 25 APRIL 1958 REVISED (A) 31 OCTOBER 1960

P.A. ARMY-AT Other Code NAVY-YD AF-85	INTERNATIONAL INTEREST	TITLE	MILITARY STANDARD
		FERRULE, ELECTRICAL CONDUIT: SPARK PLUG CABLE (OTHER THAN AIRCRAFT)	MS 39018
PROCUREMENT SPECIFICATION	SUPERSEDES	SHEET 2	OF 2
NONE			