

**OAR**

**MARINE**

# Service Manual

**MCE**

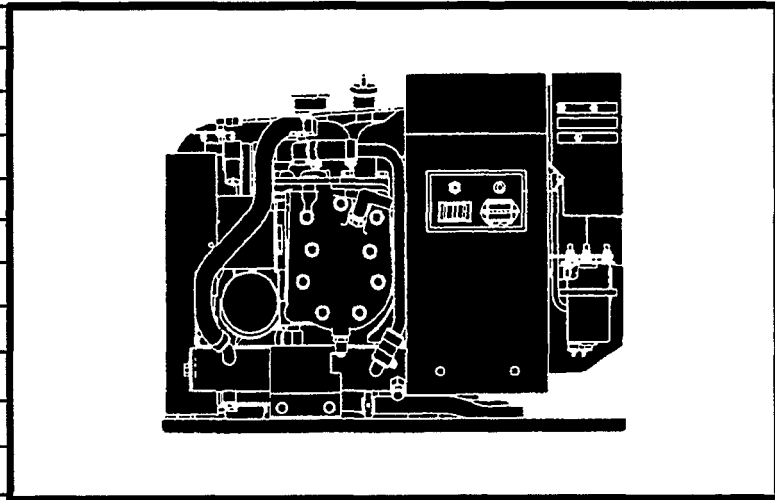
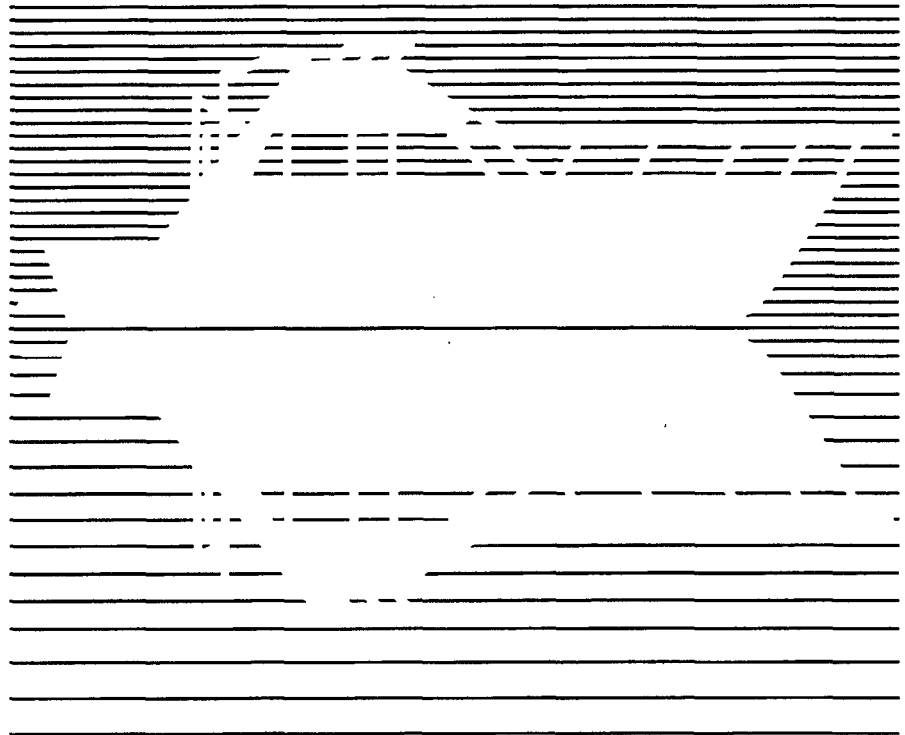

# Safety Precautions

---

Before operating the generator set, read the Operator's Manual and become familiar with it and your unit. **Safe and efficient operation can be achieved only if the unit is properly operated and maintained.** Many accidents are caused by failure to follow fundamental rules and precautions.

Throughout this manual you will notice symbols which alert you to potentially dangerous conditions to the operator, service personnel, or the equipment itself.

**▲ DANGER** *This symbol warns of immediate hazards which will result in severe personal injury or death.*

**▲ WARNING** *This symbol refers to a hazard or unsafe practice which can result in severe personal injury or death.*

**▲ CAUTION** *This symbol refers to a hazard or unsafe practice which can result in personal injury or product or property damage.*

**FUEL, ENGINE OIL, AND FUMES ARE FLAMMABLE AND TOXIC.** Fire, explosion, and personal injury can result from improper practices.

- Benzene and lead, found in some gasoline, have been identified by some state and federal agencies as causing cancer or reproductive toxicity. When checking, draining or adding gasoline, take care not to ingest, breathe the fumes, or contact gasoline.
- Used engine oils have been identified by some state or federal agencies as causing cancer or reproductive toxicity. When checking or changing engine oil, take care not to ingest, breathe the fumes, or contact used oil.
- Do not fill fuel tanks with the engine running. Do not smoke around the generator set area. Wipe up any oil or gas spills. Do not leave oily rags in engine compartment or on the generator set. Keep this and surrounding area clean.
- Inspect fuel system before each operation and periodically while running.
- Equip the engine fuel supply with a positive fuel shutoff.
- Always disconnect the battery ground (-) lead first and reconnect it last. Make sure you connect the battery correctly. A direct short across the battery terminals can cause an explosion. Do not smoke while servicing batteries. Hydrogen gas given off during charging is very explosive.
- Keep a fire extinguisher available in or near the engine compartment and in other areas throughout the vessel. Use the correct extinguisher for the area. For most types of fires, an extinguisher rated ABC by the NFPA is available and suitable for use on all types of fires except alcohol.

## EXHAUST GASES ARE DEADLY

- Provide adequate ventilation. Equip the bilge with a power exhauster.
- Be sure propulsion and generator set engine exhaust systems are free of leaks. Perform thorough, periodic inspections of the exhaust system and repair leaks immediately. Exhaust gases are deadly.
- Never sleep in the vessel with the generator set running unless the vessel is equipped with an operating carbon monoxide detector.

## HOT COOLANT CAN CAUSE SEVERE PERSONAL INJURY

- Hot coolant is under pressure. Do not loosen the coolant pressure cap while the engine is hot. Let the engine cool before opening the pressure cap.

## MOVING PARTS CAN CAUSE SEVERE PERSONAL INJURY OR DEATH.

- Do not remove any belt guards or covers with the unit running.
- Keep hands and loose clothing away from moving parts. Do not wear jewelry while servicing any part of the generator set.
- Never step on the generator set (as when entering or leaving the engine compartment). It can stress and break unit components, possible resulting in dangerous operating conditions. . . from leaking fuel, leaking exhaust fumes, etc.
- Before performing any maintenance on the generator set, disconnect its batteries to prevent accidental starting. Do not disconnect or connect battery cables if fuel vapors are present. Ventilate the generator set compartment or bilge thoroughly with the power exhauster.

## ELECTRICAL SHOCK WILL CAUSE SEVERE PERSONAL INJURY OR DEATH

- Do not make adjustments in the control panel or on engine with unit running. High voltages are present. Work that must be done while unit is running should be done only by qualified service personnel standing on dry surfaces to reduce shock hazard.
- DO NOT CONNECT THE GENERATOR SET TO THE PUBLIC UTILITY OR TO ANY OTHER ELECTRICAL POWER SYSTEM. Electrocution or damage to property can occur at a site remote from the boat where line or equipment repairs are being made if the set is connected to that power system. An approved transfer switch must be used if more than one power source is to be made available to service the boat.
- Do not work on this equipment when mentally or physically fatigued, or after consuming any alcohol or drug that makes the operation of equipment unsafe.

# Table of Contents

---

SECTION	TITLE	PAGE
	<b>SAFETY PRECAUTIONS</b> .....	Inside Front Cover
1	<b>INTRODUCTION</b> .....	1-1
2	<b>SPECIFICATIONS</b> .....	2-1
3	<b>DIMENSIONS AND CLEARANCES</b> .....	3-1
4	<b>TORQUE SPECIFICATIONS</b> .....	4-1
5	<b>PREPARING TO SERVICE</b> .....	5-1
	Troubleshooting .....	5-1
	Special Tools .....	5-1
	Safety Considerations .....	5-1
	Removing the Set from the Boat .....	5-2
6	<b>ENGINE - PRIMARY SYSTEMS</b> .....	6-1
	General .....	6-1
	Exterior Panel Removal .....	6-1
	Exhaust System .....	6-2
	Cooling System .....	6-3
	Ignition System .....	6-7
	Crankcase Ventilation System .....	6-9
	Lubrication System .....	6-10
	Fuel System .....	6-10
	Electric Starter .....	6-17
	Troubleshooting Engine Primary Systems .....	6-19
7	<b>CONTROL SYSTEM</b> .....	7-1
	General .....	7-1
	Components .....	7-1
	Sequence of Operation .....	7-2
	Control Troubleshooting .....	7-4
8	<b>GENERATOR</b> .....	8-1
	Principal of Operation .....	8-2
	Generator Service .....	8-3
	Generator Troubleshooting .....	8-9
9	<b>ENGINE - BLOCK ASSEMBLY</b> .....	9-1
	General .....	9-1
	Cylinder Heads .....	9-1
	Valve System .....	9-1
	Piston/Rod Assemblies .....	9-6
	Flywheel .....	9-10
	Gear Cover .....	9-10
	Governor Cup .....	9-11
	Timing Gears and Camshaft .....	9-11
	Lubrication System .....	9-12
	Cylinder Block .....	9-13
	Bearings .....	9-15
	Oil Seals .....	9-16
	Crankshaft .....	9-16
10	<b>SERVICE CHECKLIST</b> .....	10-1

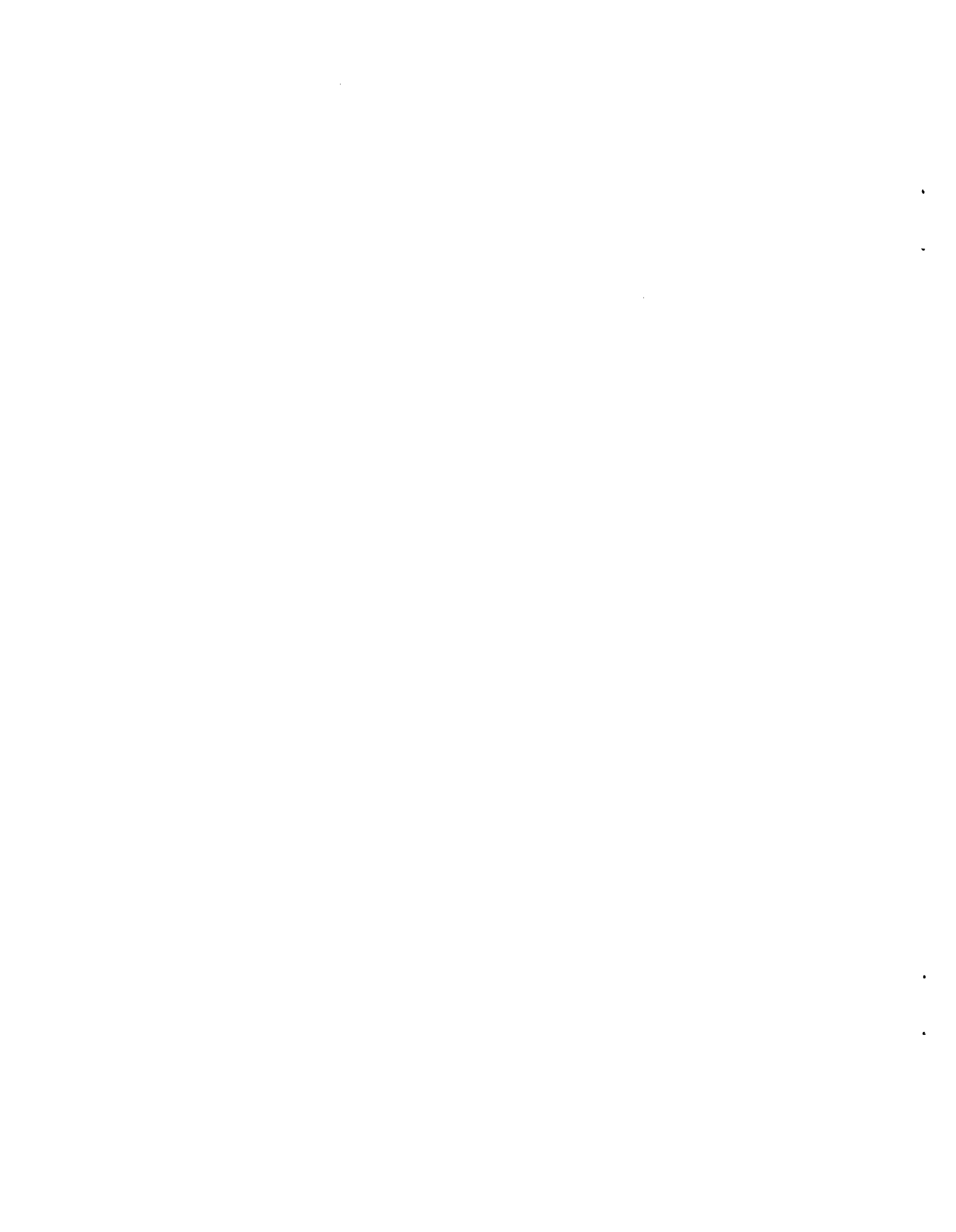

# Section 1. Introduction

---

## ABOUT THIS MANUAL

This is the service manual for Onan MCE marine generator sets. It covers troubleshooting, adjustments, repairs and overhauling of the engine, generator and control systems. Refer to the following publications for more information:

- Electrical/Mechanical Fundamentals, No. 932-0408
- Onan Generator Training Manual, No. 932-0404
- Onan Technical Bulletin, No. T-021
- MCE Operator's Manual, No. 927-0124
- MCE Installation Manual, No. 927-0600

The installation must comply with the applicable codes and standards for marine installations.

Read all service procedures completely before beginning any repair work, and observe all precautions.

Always use genuine Onan replacement parts, obtained from an authorized Onan dealer or distributor. Other replacement parts may not perform to Onan specifications. Only genuine Onan replacement parts have been tested for dependable operation on this equipment. To help you, the dealer or distributor will need to know the model and serial numbers found on the nameplate.

**▲WARNING** *Faulty service can lead to severe injury or death or damage to the equipment or boat. Service must be performed by qualified persons.*

*To maintain compliance with U.S.C.G. safety requirements use Onan supplied replacement parts only.*



# Section 2. Specifications

---

## GENERATOR DETAILS

Type .....	Revolving Field, 4-Pole, Self-Excited
Standby Ratings:	
60 Hertz, 6.5 MCE .....	6.5 kW, (6.5 kVA @ 1.0 PF), 1 phase, 120 V or 120/240 V
60 Hertz, 4.5 MCE .....	4.5 kW, (4.5 kVA @ 1.0 PF), 1 phase, 120 V or 120/240 V
50 Hertz, 5.0 MCE .....	5.0 kW, (5.0 kVA @ 1.0 PF), 1 phase, 220 V or 110/220 v
Frequency Regulation .....	5% (3 Hertz)
AC Voltage Regulation .....	±5%

## ENGINE DETAILS

Engine Type .....	Onan® MCE, 2-Cylinder Opposed
Engine Speed (r/min) .....	1800/1500
Exhaust Outlet Hose Size .....	2.0 in. (50.8 mm)
Fuel .....	Unleaded, 88 Octane
Fuel Inlet Size .....	1/4 - 18 NPT
Fuel Consumption, Average @ Full Load:	
60 Hertz, 6.5 MCE .....	1.3 gph (5.0 lph)
60 Hertz, 4.5 MCE .....	1.0 gph (3.8 lph)
50 Hertz, 5.0 MCE .....	1.1 gph (4.2 Lph)
Fuel Inlet Size .....	1/4-18 NPTF
Fuel Return Outlet Size .....	1/8-27 NPT
Battery Requirements:	
Voltage .....	12
Minimum Cold Cranking Amps @ 0° F (-18° C) .....	360
Maximum Charging Circuit Output .....	10 Amps, Regulated
Cooling System:	
Capacity, Heat Exchanger System .....	3 Quarts (2.8 L)
Heat Rejection:	
60 Hertz @ Load, Block & Exhaust Manifold .....	800 BTU/min
50 Hertz @ Load, Block & Exhaust Manifold .....	650 BTU/min
Cooling Flow Rate, 60 Hertz:	
Heat Exchanger System, Thermostat Open .....	2.2 gpm (8.3 l/min)
Sea Water, Heat Exchanger System .....	3.0 gpm (11.4 l/min)
Sea Water Cooling System .....	3.0 gpm (11.4 l/min)
Cooling Flow Rate, 50 Hertz:	
Heat Exchanger System, Thermostat Open .....	2.2 gpm (8.3 l/min)
Sea Water, Heat Exchanger System .....	2.5 gpm (9.5 l/min)
Sea Water Cooling System .....	2.5 gpm (9.5 l/min)
Sea Water Pump Dry Lift, Maximum .....	3 Ft (0.9 m)
Sea Water Inlet Hose Size .....	0.75 in. (19 mm)
Engine Oil Capacity With Filter .....	3 Quarts (2.8 L)
Total Air Required (Generator Cooling and Combustion):	
60 Hertz .....	146 ft <sup>3</sup> /min (4.1 m <sup>3</sup> /min)
50 Hertz .....	120 cu. ft./min (3.4 m <sup>3</sup> /min)
Spark Plug Gap .....	0.025 in. (0.64 mm)
Valve Clearance (Intake and Exhaust) .....	0.009-0.011 in. (0.23-0.28 mm)





# Section 3. Dimensions and Clearances

---

All clearances given at room temperature of 70°F (21°C). All dimensions in inches (approximate millimetre dimensions in parentheses) unless otherwise specified.

## CYLINDER BLOCK

Cylinder Bore Honed Diameter .....	3.2490-3.2500	(82.525-82.550)
Maximum Allowable		
Taper .....		0.005 (0.127)
Out-of-Round .....		0.002 (0.051)
Main Bearing Inside Diameter (Without bearing) .....	2.187-2.188	(55.55 - 55.58)
Main Bearing Inside Diameter (Installed) .....	2.0020-2.0030	(50.85 - 50.88)
Camshaft Bearing Bore (Bearing installed) .....	1.3760-1.3770	(34.95 - 34.98)

## CRANKSHAFT

Main Bearing Journal Diameter .....	1.9992-2.0000	(50.78 - 50.80)
Main Bearing Clearance .....	0.0025-0.0038	(0.064-0.097)
Connecting Rod Journal Diameter .....	1.6252-1.6260	(41.28 - 41.30)
Connecting End Play .....	0.006-0.012	(0.152-0.305)

## CONNECTING ROD

Large Bore Diameter (Without bearing installed and rod bolts properly torqued) .....	1.7505-1.7510	(44.46 - 44.48)
Connecting Rod Side Clearance .....	0.0020-0.0160	(0.051-0.406)
Piston Pin Bushing Bore (Without bearing) .....	0.8115-0.8125	(20.61-20.64)
Piston Pin Bushing Bore with Bearing, (Finished bore) .....	0.7504-0.7508	(19.05-19.07)
Bearing to Crankshaft Clearance		
Nodular Iron Rod .....	0.0005-0.0023	(0.013-0.058)
Aluminum Rod .....	0.0020-0.0033	(0.051-0.084)

## CAMSHAFT

Bearing Journal Diameter .....	1.3740-1.3745	(34.90-34.91)
Bearing Clearance .....	0.0015-0.0030	(0.038 - 0.076)
End Play .....	0.0030-0.0120	(0.076-0.305)
Camshaft Lift .....		0.300 (7.62)

## PISTON

Clearance in Cylinder		
Measure 90° to pin 0.10 inch below oil ring .....	0.0025-0.0045	(0.064 - 0.114)
Piston Pin Bore .....	0.7502-0.7506	(19.055-19.065)
Ring Groove Width		
Top 1 Compression Ring .....	0.0960-0.0970	(2.438-2.464)
No. 2 Compression Ring .....	0.0955-0.0965	(2.426-2.451)
No. 3 Oil Control Ring .....	0.188-0.189	(4.775-4.801)

# Section 3. Dimensions and Clearances

(Continued)

<b>PISTON PIN</b>		
Clearance in Piston .....	Thumb Push Fit	
Clearance in Connecting Rod	0.0002-0.0007	(0.005-0.018)
Diameter .....	0.7500-0.7502	(19.05-19.06)
<b>PISTON RINGS</b>		
Clearance		
Top Groove .....	0.002-0.008	(0.051-0.203)
Ring End Gap in Cylinder .....	0.010-0.020	(0.254-0.508)
<b>INTAKE VALVE</b>		
Stem Diameter .....	0.3425-0.3430	(8.70-8.71)
Clearance (Stem to Guide) .....	0.0010-0.0025	(0.025-0.064)
Valve Face Angle		44°
<b>INTAKE VALVE SEAT</b>		
Valve Seat Width .....	0.031-0.047	(0.787-1.194)
Valve Seat Angle .....		45°
<b>EXHAUST VALVE</b>		
Stem Diameter .....	0.3410-0.3415	(8.661-8.674)
Clearance (Stem to Guide) .....	0.0025-0.004	(0.064-0.102)
Valve Face Angle .....		44°
<b>EXHAUST VALVE SEAT</b>		
Seat Cylinder Head Bore Diameter .....	1.1890-1.1900	(30.20-30.23)
Seat Outside Diameter .....	1.1920-1.1930	(30.28-30.30)
Valve Seat Width .....	0.031-0.047	(0.787-1.194)
Valve Seat Angle .....		45°
<b>VALVE GUIDE</b>		
Inside Diameter .....	0.344-0.346	(8.74-8.79)
<b>TAPPET</b>		
Body Diameter .....	0.7475-0.7480	(18.99-19.00)
Bore Diameter .....	0.7505-0.7515	(19.06-19.09)
Clearance in Bore .....	0.0015-0.003	(0.038-0.076)
<b>VALVE SPRINGS INTAKE AND EXHAUST</b>		
Valve Spring Free Length (Approx.) .....	1.662 (42.21)	
Valve Spring Length		
Valve Open .....	1.125 (28.58)	
Valve Closed .....	1.375 (34.93)	
Spring Load @ 1.375 inch (Valve Closed) .....	38 - 42 lb	(17-19 kg)
Spring Load @ 1.125 inch (Valve Open) .....	71-79 lb	(32-36 kg)
<b>GEAR BACKLASH</b>		
Timing Gear .....	0.002-0.003	(0.051-0.076)
Oil Pump Gear .....	0.002-0.005	(0.051-0.127)

# Section 4. Torque Specifications

---

Use engine oil as a lubricant for all threads except for the spark plugs and rotor through-stud.

PART	TORQUE
	Ft-lbs (Nm)
Spark plugs	7-15 (10-20)
Cylinder head bolts	29-31 (39-42)
Connecting rod bolts:	
Forged steel	27-29 (37-39)
Aluminum	24-26 (33-35)
Rear bearing plate bolts	20-25 (27-34)
Oil pump screws	7-9 (10-12)
Oil base bolts	28-32 (38-43)
Gearcase cover screws	10-13 (14-18)
Flywheel mounting bolt	50-55 (68-75)
Exhaust manifold screws	14-18 (19-24)
Intake manifold screws	14-18 (19-24)
Oil filter adapter screws	14-18 (19-22)
Valve cover nut	4-8 (5-11)
Carburetor mounting nuts	8-12 (11-16)
Starter mounting bolts	30-33 (41-45)
Water pump bracket screws	8-10 (11-14)
Rotor through-stud	45-50 (61-68)
Generator adapter to engine bolts	20-25 (27-34)
Adapter to generator bolts	20-25 (27-34)
Stator clamp screws	10-12 (11-16)
Vibration isolators	
Center bolt	30-33 (41-45)
Flange screws	10-12 (13-16)



# Section 5. Preparing to Service

---

## TROUBLESHOOTING

Always follow a systematic troubleshooting procedure to locate a problem before attempting to service the generator set. Several troubleshooting guides are included in this manual to help locate a problem. It should be noted that some problems can have several causes, and that a troubleshooting guide cannot anticipate all possibilities. Experience and knowledge of this equipment are essential. To help you, this manual covers the following systems separately:

- Engine - Primary Systems
- Control
- Generator
- Engine - Block Assembly

## SPECIAL TOOLS

The tools listed below are necessary in order to service the generator set. Some of these are available through an authorized Onan service center.

### Engine Tools:

Torque wrench (0-75 ft-lbs, or 0-100 N-m)  
Feeler gauge  
Pressure gauge  
Spark plug gap gauge  
Cylinder compression tester  
Flywheel puller  
Snap ring pliers  
Gear puller with puller ring  
Cylinder ridge reamer  
Combination main and cam bearing remover  
Combination main and cam bearing driver  
Oil seal guide and driver  
Piston ring compressor  
Piston ring spreader  
Cylinder hone  
Valve seat cutter

Valve spring compressor  
Valve lock replacer  
Valve seat driver  
Valve guide driver  
Piston groove cleaner  
Outside micrometer set (0 to 4 in.)  
Telescoping gauge set (1/2 to 4 in.)  
Hole gauge (0.300 to 0.400 in.)  
Plasti-Gage bearing clearance indicator (green)

### Generator and Control:

Lead or dead-blow hammer  
Battery hydrometer  
VOM multi-tester  
Insulation resistance test meter  
Frequency meter  
Armature growler  
Load test panel and leads

## SAFETY CONSIDERATIONS

Think through and understand the hazards involved in working with generator sets. Read through the safety precautions listed on the inside cover and familiarize yourself with the hazards listed in Table 5-1. A safety-conscious attitude is necessary to avoid injury to yourself and others. Observe the following safeguards.

- **Use personal protection:** Wear appropriate protective safety equipment, such as:
  - Safety shoes
  - Gloves
  - Safety glasses

Do not wear rings or jewelry, and do not wear loose clothing that can get caught in equipment.

- **Reduce the hazard:** A safe, orderly workshop area and well-maintained equipment reduce the likelihood for an accident. Keep guards and shields in place on machinery, and maintain equipment in good working condition. Store flammable liquids in approved containers, away from flames, sparks, pilot flames, arc-producing equipment or other ignition sources. Keep the workshop clean and well-lighted, and provide adequate ventilation.

**TABLE 5-1  
HAZARDS AND THEIR SOURCE**

<ul style="list-style-type: none"> <li>● Fire and explosions               <ul style="list-style-type: none"> <li>-Leaking fuel</li> <li>-Hydrogen gas from battery</li> <li>-Oily rags improperly stored</li> <li>-Flammable liquids improperly stored</li> </ul> </li> <li>● Burns               <ul style="list-style-type: none"> <li>-Hot exhaust pipes</li> <li>-Hot engine and generator surfaces</li> <li>-Hot engine oil/coolant</li> <li>-Electrical short</li> </ul> </li> <li>● Poisonous Gases               <ul style="list-style-type: none"> <li>-Carbon monoxide from faulty exhaust system</li> <li>-Operating generator set where exhaust gases can accumulate</li> </ul> </li> </ul>	<ul style="list-style-type: none"> <li>● Electrical Shock (AC)               <ul style="list-style-type: none"> <li>-improper generator set load connections</li> <li>-Faulty wiring</li> <li>-Faulty electrical appliance</li> <li>-Faulty generator set wiring</li> </ul> </li> <li>● Rotating Machinery               <ul style="list-style-type: none"> <li>-Belt guard not in place</li> </ul> </li> <li>● Slippery Surfaces               <ul style="list-style-type: none"> <li>-Leaking or spilled oil</li> <li>-Water/coolant leaks</li> </ul> </li> <li>● Heavy Objects               <ul style="list-style-type: none"> <li>-Removing generator set from boat</li> <li>-Removing heavy components</li> </ul> </li> </ul>
--	---

- **Develop safe work habits:** Unsafe work habits are the leading cause of accidents involving tools and machines. Be familiar with the equipment, and know how to use it safely. Use the correct tool for the job, and check its condition before use. Observe the warnings in this manual. If possible, do not work alone. Do not take risks.
- **Be prepared to respond to an emergency:** The Red Cross, police and fire departments and other agencies offer courses in first aid, CPR and fire control. Take advantage of these opportunities to learn how to respond to an emergency.

**▲WARNING** To maintain compliance with U.S.C.G. safety requirements use Onan supplied replacement parts only.

### **REMOVING THE SET FROM THE BOAT**

Contact the boat manufacturer if there is no obvious way to remove the set for service. Use the lifting eye provided.

Removal of the set will involve disconnecting the battery (negative [-] cable first), fuel line, sea water line, exhaust tube, control wiring and electrical load cables. Make sure the fuel shutoff valve and sea cock are fully closed before disconnecting the lines.

**▲WARNING** Gasoline is highly flammable. Make sure the fuel shutoff valve is closed to prevent spillage or escape of gasoline vapors. Do not smoke near gasoline tanks or equipment. Keep flames, sparks, pilot flames, electrical arcs and other sources of ignition away.

# Section 6. Engine — Primary Systems

## General

The primary systems of the engine are:

- Exhaust
- Cooling
- Ignition
- Crankcase Ventilation
- Lubrication
- Fuel
- Starting

The primary systems can usually be serviced without major disassembly or removal of the set from the boat. Use the troubleshooting guide at the end of this section to help locate problems related to the primary systems. The *Generator* and *Control* sections also include troubleshooting guides.

## EXTERIOR PANEL REMOVAL

Most service procedures will require removal of some or all of the exterior panels (Figure 6-1). (Some models only have a belt guard secured by seven screws.)

- The side panels are secured by four tapered studs pushed into rubber grommets. Pull the panels out at the bottom and then push up to remove.
- The DC and AC panels are secured by studs and grommets at the top and screws at the bottom. Remove the screws and then push up to remove.
- The top panel is secured by four studs and grommets. Pull up to remove.
- The belt guard can be removed by removing the four screws.

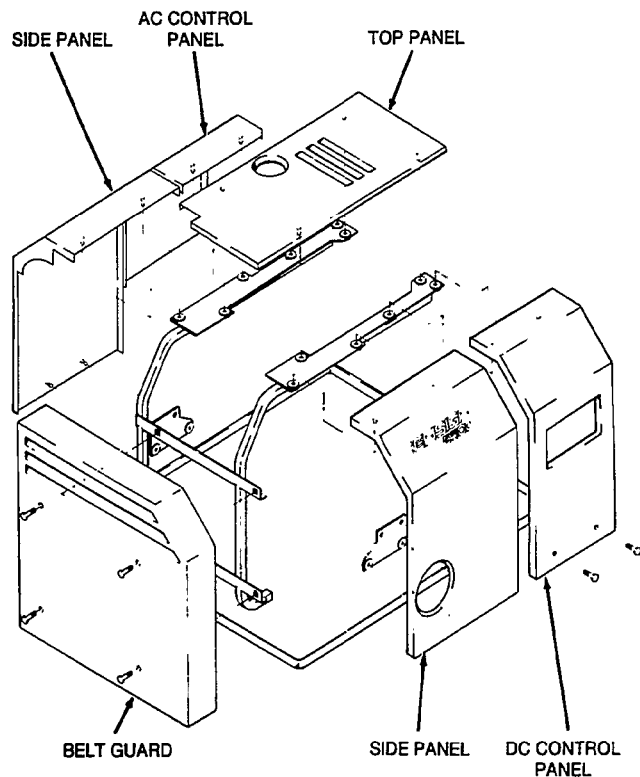

M-1814

FIGURE 6-1. EXTERIOR PANEL REMOVAL

## EXHAUST SYSTEM

These generator sets have been designed for installation with a hydrodynamic muffler. The exhaust manifold is water-jacketed, and the full flow of sea water (the term used in this text for flotation water, whether fresh water or sea water) for engine cooling is discharged into the

exhaust gas stream through ports at the exhaust outlet of the engine. Exhaust pressure is used to expel the water out the through-the-hull exhaust fitting. Figure 6-2 illustrates a typical exhaust / cooling installation. Refer to the *Installation Manual* for important installation requirements.

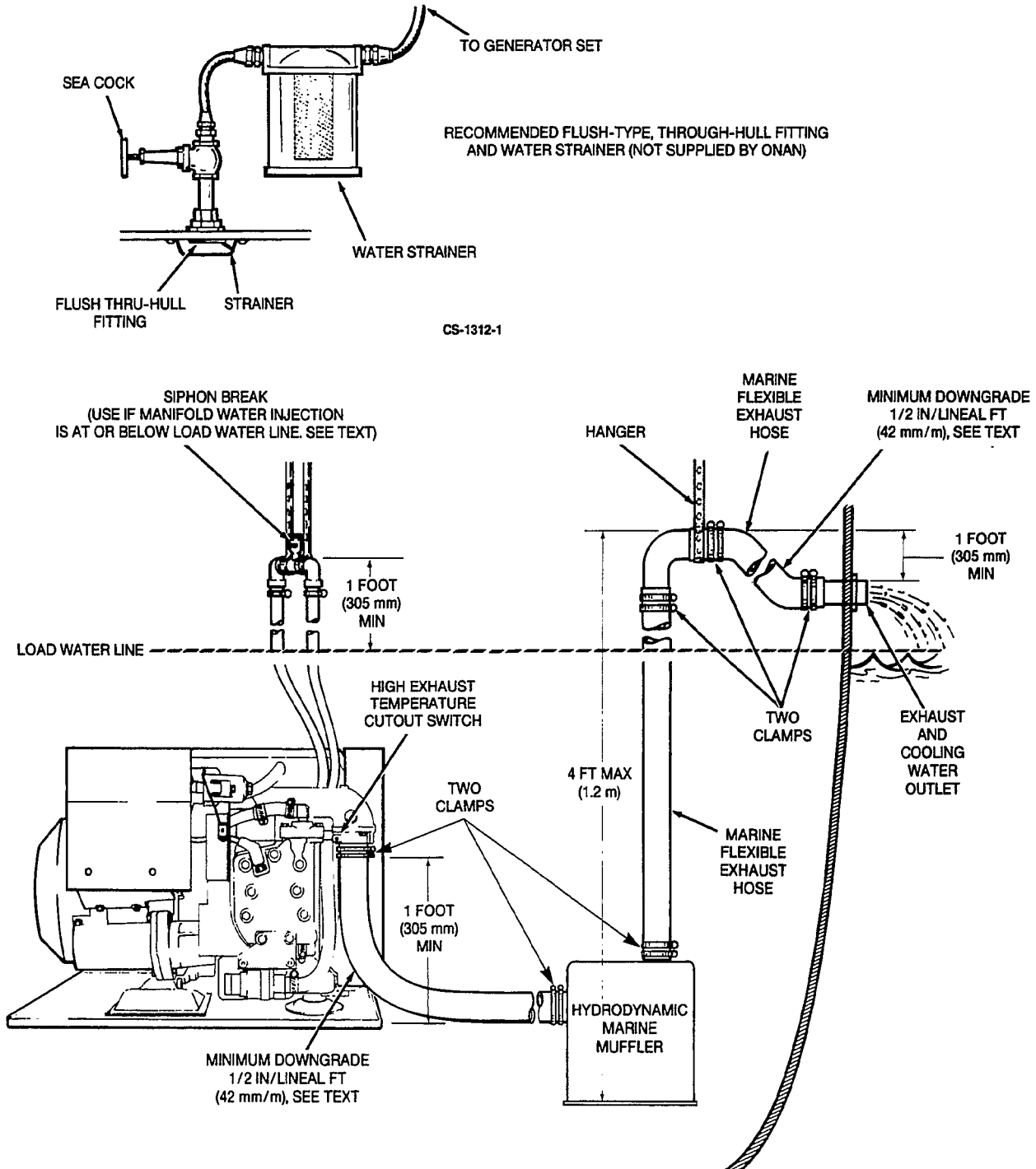

FIGURE 6-2. TYPICAL EXHAUST/COOLING INSTALLATION



**⚠ WARNING** *Improper installation, careless connection of hoses or failure to check for water and exhaust leaks can lead to flooding of the engine and boat or to severe sickness or death from exhaust gas (carbon monoxide).*

The full flow of engine cooling water is necessary to keep the exhaust gases cool enough for the exhaust system to handle. The high exhaust temperature switch shuts down the engine to protect the exhaust system from high exhaust temperatures if the flow of cooling water fails. Failure could be the result of a closed sea water cock, clogged water filter, defective water pump, broken or loose pump drive belt, broken hoses or clogged engine or heat exchanger passages.

Service involves checking the exhaust and cooling systems for water and exhaust leaks and tightening clamps or replacing defective fittings or hose sections. The siphon break (if part of the system) should be checked for free movement of the valve by removing the screw-on cap, and replacing it if the valve is sticky.

If the high exhaust temperature switch has shut down the engine at any time, examine the exhaust hose and fittings and replace any sections that have been damaged by heat. The fault reset button on the control panel has to be reset to restore operation whenever the switch has functioned.

## COOLING SYSTEM

The engine is cooled directly by sea water or by a closed system coolant in conjunction with a coolant/sea water heat exchanger. The sea water used to cool the engine or heat exchanger is discharged into the exhaust gas stream, to cool the exhaust gas, and is expelled by exhaust pressure. Figure 6-2 illustrates a typical exhaust/cooling installation.

### Closed, Heat Exchanger Cooling System

Figure 6-3 illustrates the closed, heat exchanger cooling system.

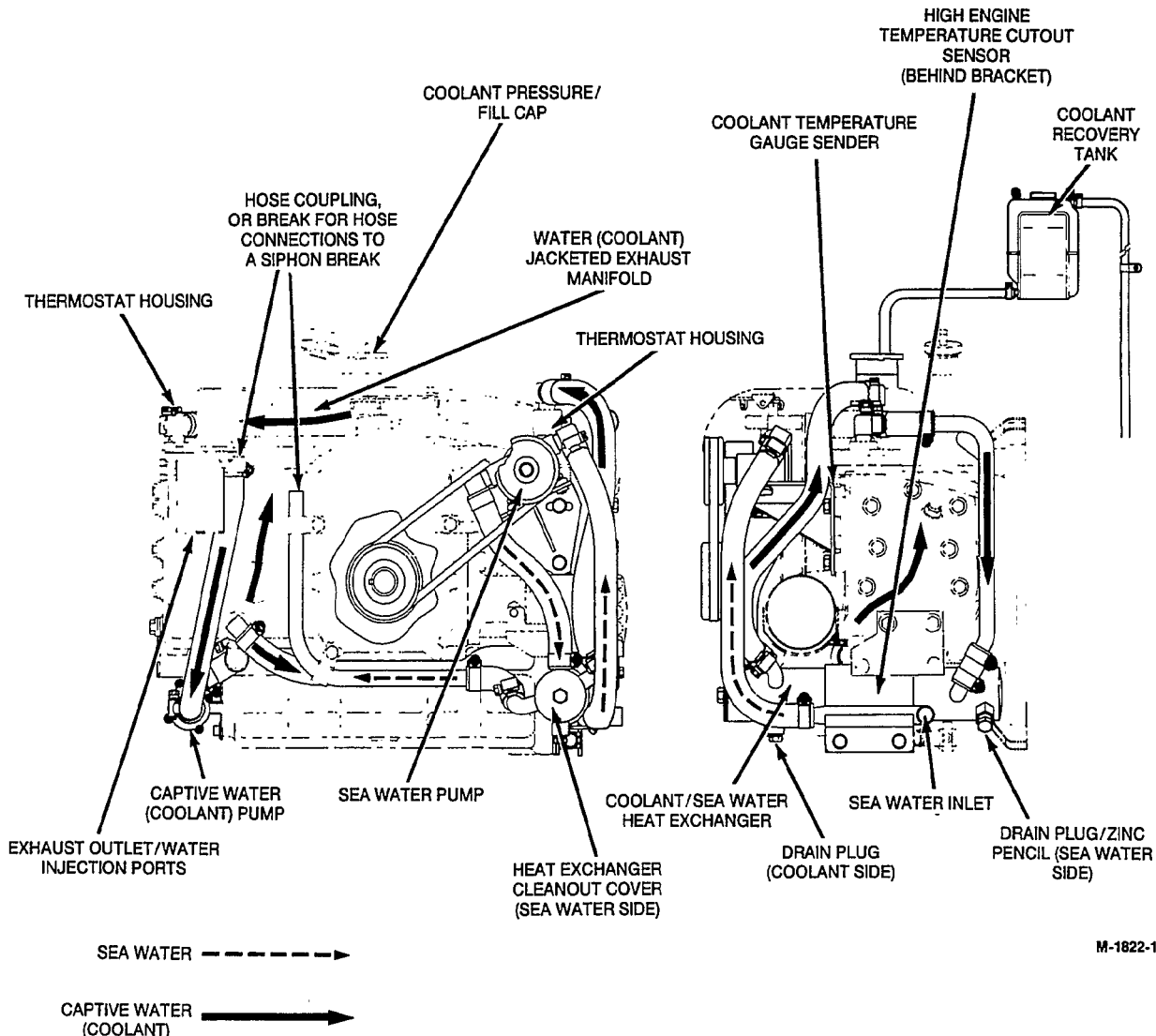

FIGURE 6-3. CLOSED, HEAT EXCHANGER COOLING SYSTEM

A 12V battery powered electric pump circulates coolant between the engine and the coolant/sea water heat exchanger. Two thermostats regulate the engine operating temperature by controlling the flow of coolant. As the engine warms and cools, the coolant expands and contracts, pressurizing and de-pressurizing the system. The pressure cap limits coolant pressure by releasing coolant to the recovery tank. As the coolant volume contracts, the pressure cap allows the coolant in the recovery tank to siphon back into the engine. The coolant system is thereby kept full of coolant and free of air.

Sea water is pushed through the heat exchanger and water injection ports at the engine exhaust outlet by a belt driven pump with a neoprene impeller. To prevent flooding of the engine and the hull with sea water, a siphon break must be provided upstream of the water injection ports if they are below the load water line.

The boat installation must include a sea cock to allow service of the cooling system and a water filter to prevent abrasion of the pump and clogging of passages with dirt.

**CAUTION** *The neoprene sea water pump impeller disintegrates in a matter of seconds if the pump is run dry. Do not run the set in dry dock or shop without connecting the pump to an ample reservoir of water at a level that will keep the pump flooded.*

**Coolant:** Fill the engine coolant system with a 50/50 solution of ethylene glycol antifreeze and clean water. The antifreeze should include a rust inhibitor but not a stop-leak. A greater portion of antifreeze only degrades the heat transfer properties of the coolant and raises the freezing point. Open the air bleed valves on top of the thermostat housings to allow air to escape while filling coolant. Fill the engine through the pressure cap opening and then secure the cap and close the air bleed valves.

**CAUTION** *If the engine is cold, the thermostats will be closed and the engine may not fill completely. Run the engine a few minutes to warm it up. Check the coolant level and complete filling.*

Fill the recovery tank half way between the high and low marks. The coolant level in the recovery tank will rise and fall as the engine runs, but is okay as long as it is above the low mark.

Change coolant every year. To drain the coolant, let the engine cool, remove the pressure cap, disconnect the hoses to the coolant pump outlet and heat exchanger and remove the coolant plug in the heat exchanger.

Remove the thermostat in each head and back flush the system with clean water. If there is scale and rust, use a good cleaning compound in accordance with instructions from the supplier. Install new thermostats and gaskets, reconnect the hoses and secure the drain plug. Refill with new coolant. Repair any coolant leaks before placing the set in service.

**WARNING** *Hot coolant is under pressure and can cause burns if allowed to escape. Let the engine cool before removing the pressure cap.*

**Pressure Cap:** Pressurizing the coolant allows operation at higher temperatures for better efficiency and engine life. It is recommended that the cap be replaced every two years.

**Thermostats (two):** Two thermostats, one in each cylinder head, regulate the engine operating temperature by controlling the flow of coolant (Figure 6-4), for better efficiency and engine life. It is recommended that both thermostats be replaced when the coolant is changed.

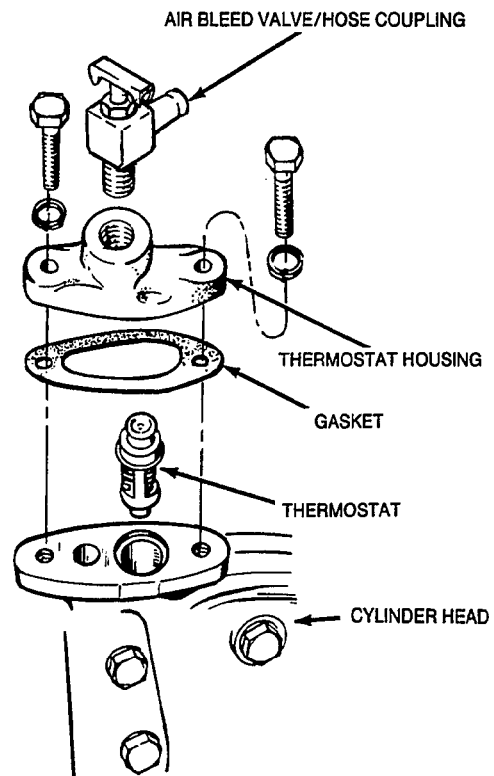

CS-1374

FIGURE 6-4. THERMOSTAT

**High Engine Temperature Sensor:** The high engine temperature sensor (Figure 6-3) senses coolant temperature and shuts down the engine when coolant temperature reaches the calibrated setting of the sensor. The fault reset button on the control panel has to be reset to restore operation.

**Coolant Temperature Gauge Sender (optional):** The coolant temperature sender (Figure 6-3) senses coolant temperature and is connected to indicate the coolant temperature on the remote control panel gauge.

**Coolant Pump:** The coolant pump (Figure 6-3) circulates the coolant between the engine and the coolant/-sea water heat exchanger. It must be replaced as a unit if it malfunctions. To remove, drain the coolant, disconnect the leads and hoses and remove the two mounting screws.

**Coolant/Sea Water Heat Exchanger:** The coolant/sea water heat exchanger (Figure 6-3) cools the engine coolant with sea water while keeping coolant and sea water segregated. Coolant flows inside the shell, around the tubes. Sea water flows through one pass of tubes and returns by the other.

The sea water side of the heat exchanger is protected from corrosion by the zinc pencil/drain plug. Check the plug at least once every other month and replace the pencil if it is less than 1/2 inch (13 mm) long (Figure 6-3).

Remove the end cap and drain plug to clean the sea water side. Take the heat exchanger to a radiator shop if it is badly fouled. Also, remove the end cap to check for impeller debris if the sea water pump has accidentally been run dry.

**Sea Water Pump:** The sea water pump is of the positive displacement type with a neoprene impeller (Figures 6-3 and 6-5). The impeller is easily replaced by removing the pump cover and pulling it out with a pair of pliers. Impeller repair kits are available from the Onan distributor. Short impeller life is usually due to abrasion from dirt in the sea water. There should always be a water filter ahead of the pump.

If the bearings are worn or the pump leaks water, complete disassembly is required, as follows:

1. After removing the pump from the set, remove the pump cover and impeller.
2. Remove the pulley, plastic end cap, and bearing and shaft retaining rings and pull the shaft out from the pulley end.
3. Remove the cam and wear plate and pry out the water seal.

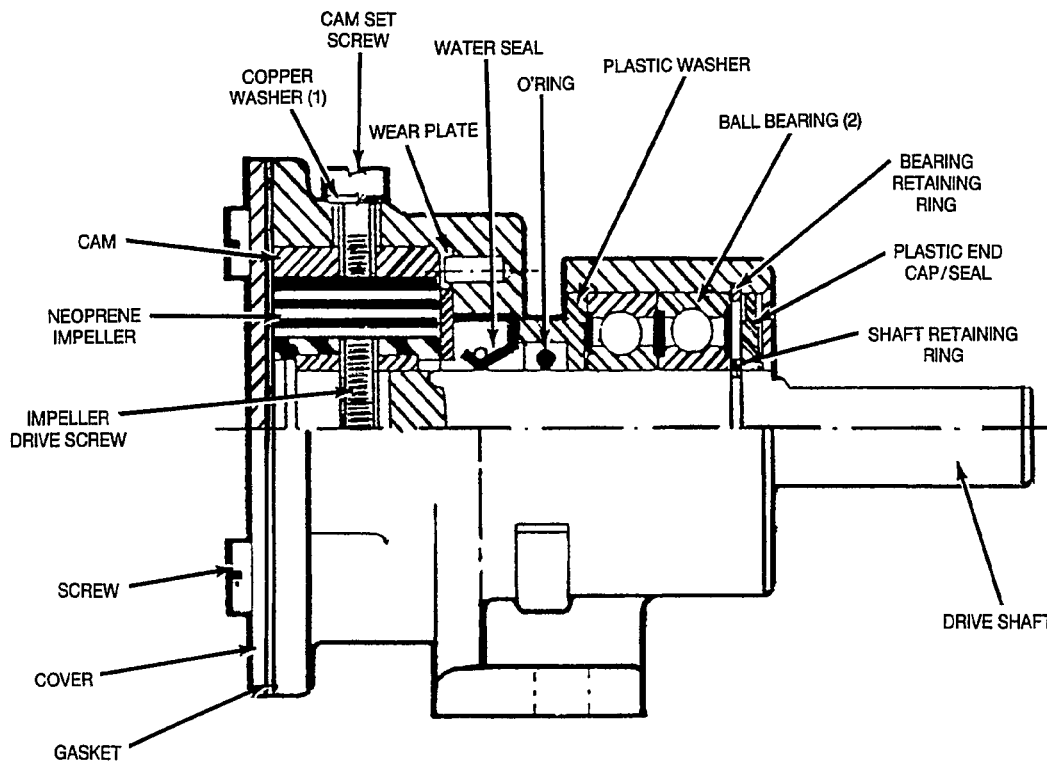

CS-1309

FIGURE 6-5. SEA WATER PUMP

To reassemble the pump, proceed as follows:

1. Press in the new water seal as shown (Figure 6-5). Use vasoline to lubricate the bore. Also lubricate the seal lip to prevent abrasion when the shaft is inserted.
2. Press the new bearings onto the shaft from the pulley end until the retaining ring groove is clear, and snap the ring into place.
3. Install the plastic washer and O-ring from the impeller end and insert the shaft assembly into the pump housing until it bottoms. Snap the retainer ring and plastic end cap into place.
4. Assemble the wear plate, cam and impeller. Use vasoline to lubricate the impeller wear surfaces, and secure the pump cover and gasket.
5. Secure the pulley and mount the pump. Make sure the pump and engine flywheel pulleys line up. Adjust belt tension so that deflection in the middle of the span between pulleys is approximately 1/8 inches (3 mm) when a force of 7 pounds (3 Kg) is applied.

### Direct Sea Water Cooling System

Figure 6-6 illustrates the direct sea water cooling system.

**CAUTION** *Salt water can corrode the block and cause early failure of the head gaskets. Direct sea water cooling of the generator set is not recommended for boats used on salt water.*

Sea water is pushed through the engine and exhaust manifold water jackets to the water injection ports at the engine exhaust outlet by a belt driven pump with a neoprene impeller. To prevent flooding of the engine and the hull with sea water, a siphon break must be provided upstream of the water injection ports if they are below the load water line.

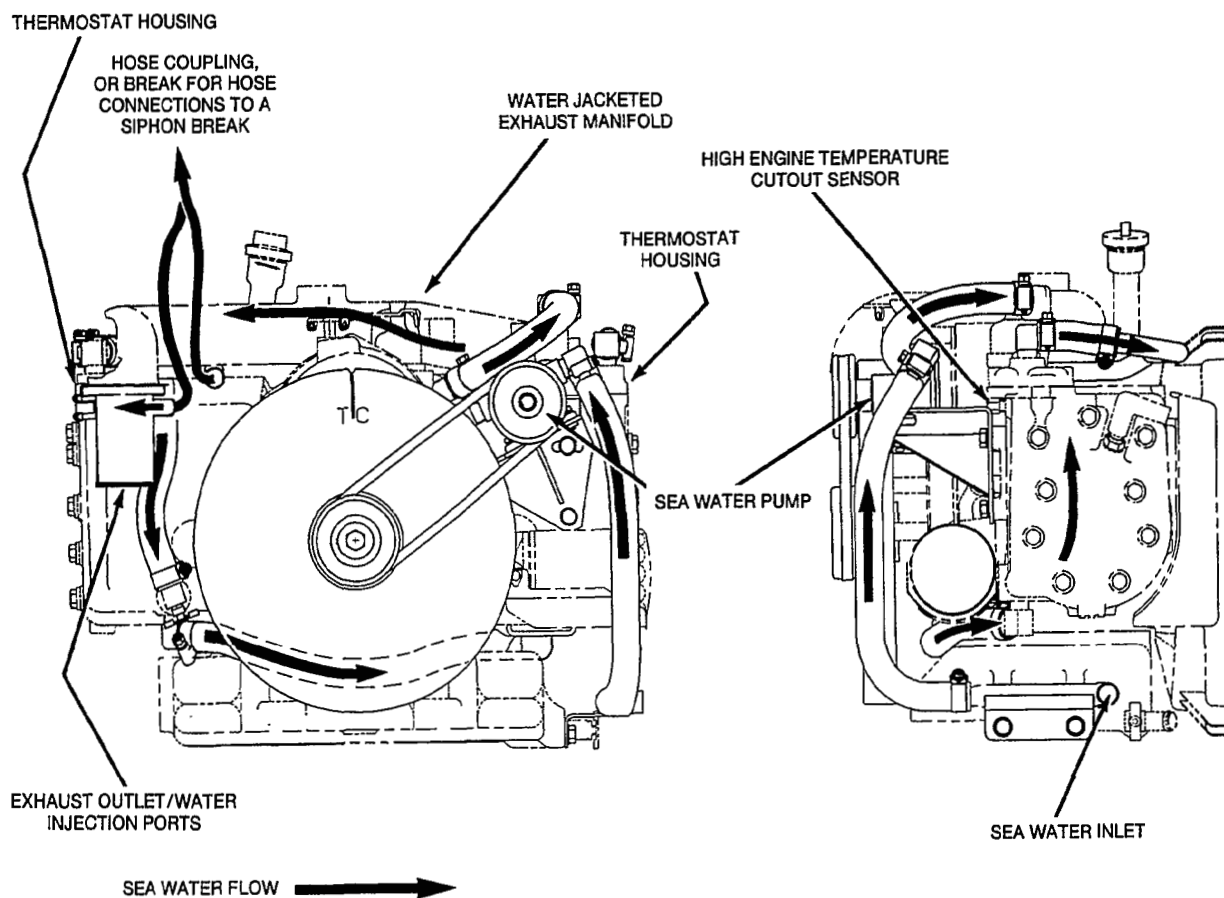

CS-1376

FIGURE 6-6. DIRECT SEA WATER COOLING SYSTEM

The boat installation must include a sea cock to allow service of the cooling system, and a sea water filter to prevent abrasion of the pump and clogging of passages with dirt.

**CAUTION** *The neoprene sea water pump impeller disintegrates in a matter of seconds if the pump is run dry. Do not run the set in dry dock or shop without connecting the pump to an ample reservoir of water at a level that will keep the pump flooded.*

The sea water pump and thermostats are serviced as described above for closed heat exchanger systems. Refer to the Operator's Manual regarding cleaning of the engine water jackets.

## IGNITION SYSTEM

The ignition system is powered by the 12 V starting battery, and consists of a magnetic trigger ring on the crankshaft (behind the flywheel), electronic ignition module mounted on the gear case, ignition coil, capacitor, spark plug cables and spark plugs. Both spark plugs fire at the same time, once each revolution, 20 degree BTC.

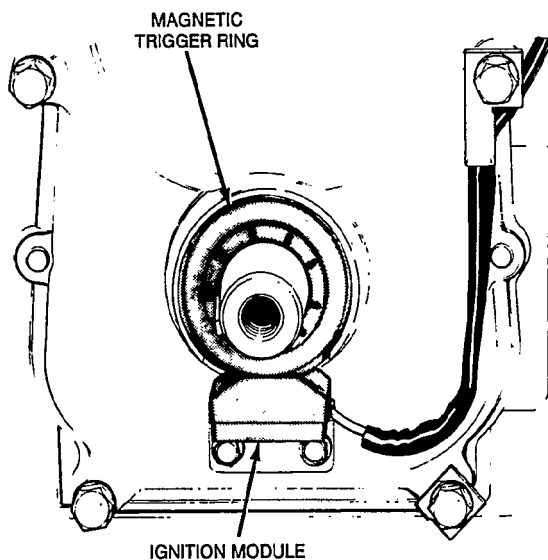

ES-1670-1

FIGURE 6-7. IGNITION TRIGGER RING AND MODULE

If the ignition system is suspected of malfunctioning, service it as follows:

1. Check all electrical connections to make sure they are clean and tight. Go to Step 2 if connections are good.

**WARNING** *Ignition sparks can cause fire or explosion. Do not run the following test until you are sure that all gasoline vapors have been removed from the bilge. Run the exhaust fan at least 15 minutes before testing, and keep the hatches open during the test.*

**Do not test by sparking the system to the engine block or frame. Use an inductive spark tester.**

2. Connect an inductive spark tester to one of the spark plug cables and crank the engine for 5 seconds to determine if that spark plug is firing. Repeat the test for the other spark plug. If both spark plugs are firing, and ignition timing is within specifications, the problem is not in the ignition system. If only one spark plug fires, the problem is with the spark plug, cable or ignition coil. Go to Step 5 if neither spark plug fires.

**WARNING** *Rotating parts can cause severe injury. Avoid contact with the flywheel and pump drive belt. Replace the belt guard when the tests have been completed.*

3. Remove and examine the spark plug that did not fire. The source of the problem can often be pinpointed by inspecting the spark plug, as follows:

- **One plug carbon fouled:** Check for an open spark plug cable or for low compression.
- **Black soot deposits:** Check for faulty choke operation or an overly rich fuel mixture, clogged resonator or flame arrester.
- **Oil fouled:** Check for a faulty crankcase breather, worn rings, or worn valve guides.
- **Burned or overheated:** Check for leaking intake manifold gaskets, lean fuel mixture, wrong spark plug heat range or faulty ignition timing.
- **Chipped insulator:** Check for advanced ignition timing or damage from setting gap. Bend only the side electrode when setting the gap.
- **Splash fouled:** Check for accumulated deposits in the combustion chamber.
- **Light tan or grey deposits:** Normal color.

Replace faulty plugs and repeat the test in Step 2. If the spark plugs do not fire, go to Step 4.

4. Measure the resistance of the spark plug cables. Acceptable resistances are:

- 1,350-6,100 ohms for the short cable
- 3,690-15,500 ohms for the long cable.

Replace a faulty spark plug cable and repeat the test in Step 2. Go to Step 5 if the cables are good but the spark plug does not fire.

5. Test the ignition module as follows:

- Remove the spark plugs to make turning the engine easier.
- Connect the positive (+) side of a voltmeter to the negative (-) terminal of the ignition coil (larger of the two screw terminals) and the negative (-) side of the voltmeter to engine ground.

- Connect a jumper lead from B+ to the positive (+) side of the ignition coil.
- Rotate the flywheel clockwise by hand. Voltage should alternate between battery voltage and 1 - 1.5 volts each revolution. Replace the ignition module if the voltage does not alternate. Go to Step 6 if the ignition module is good but the spark plugs do not fire.

6. Test the resistances of the primary and secondary windings of the ignition coil. Remove all leads and cables from the terminals (Figure 6-8). For accurate resistance measurements, the coil should be at normal room temperature (70°F [21°C]). Acceptable resistances are as follows:

- 2.9-3.6 ohms for the primary windings of the coil
- 14,500-19,800 ohms for the secondary windings of the coil.

Replace the coil if either winding is faulty. If the the engine does not run, or runs roughly, go to Step 7.

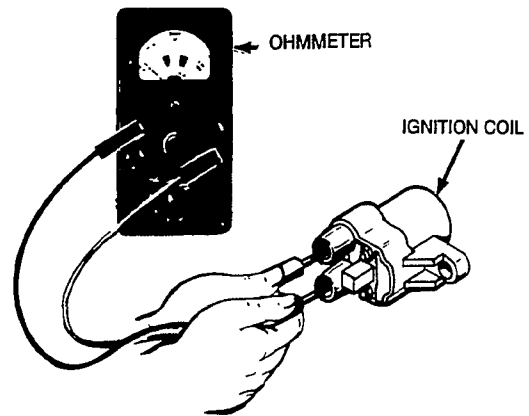

ES-1687

FIGURE 6-8. COIL TEST

7. The ignition timing is preset at the factory and is not adjustable, but for troubleshooting, an approximate check can be made. If the engine runs, check the timing with an inductive timing light. The flywheel mark should fall between the 17° and 23° marks on the gear cover (Figure 6-9). Replace the magnetic trigger ring if the timing is off. If the engine will not run, test ignition timing as follows:

- Remove the spark plugs to make turning the engine easier.
- Connect the positive (+) side of a voltmeter to the negative (-) terminal of the ignition coil (larger of the two screw terminals) and the negative (-) side of the voltmeter to engine ground.
- Remove all leads from the positive (+) terminal of the coil.
- Use a jumper to connect the ignition module lead (the one just removed from the coil) to the battery positive (+) terminal.
- Rotate the flywheel clockwise by hand. The mark on the flywheel should fall between the 17° and 23° marks on the gearcase when the voltage jumps up to battery voltage. Repeat the test several times by continuing to rotate the flywheel clockwise.

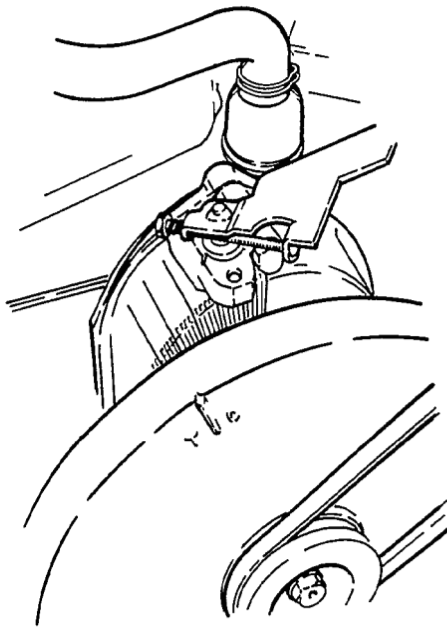

M-1827-1

FIGURE 6-9. IGNITION TIMING MARKS

## Spark Plugs

Check or replace spark plugs as recommended in the *Periodic Maintenance Schedule* in the Operator's Manual. Replace worn or fouled spark plugs.

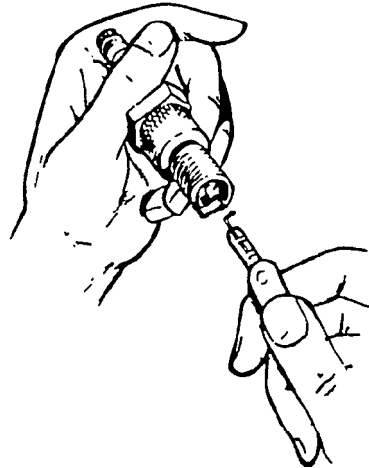

ES-1374

FIGURE 6-10. CHECKING SPARK PLUG GAP

## CRANKCASE VENTILATION SYSTEM

The crankcase breather (Figure 6-11) maintains a slight vacuum in the crankcase. It reduces oil contamination by removing **blow-by** gases from the crankcase and discharging them into the incoming air stream, which carries them to the **combustion** chamber where they are burned. Replace a fouled crankcase breather assembly, which can cause oil leaks, high oil consumption, rough idle, reduced power and sludge formation.

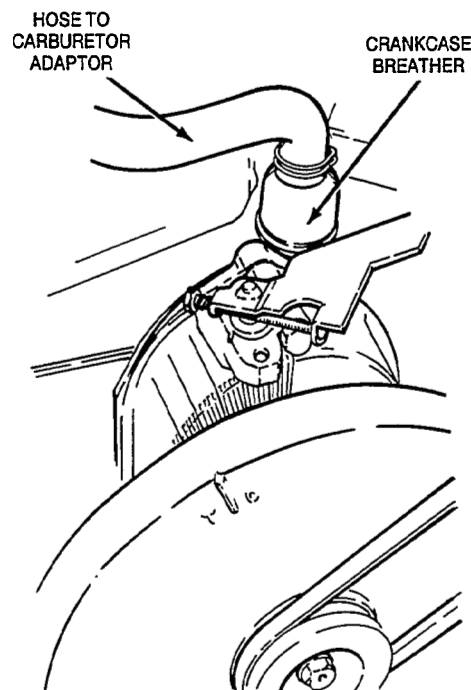

M-1827-1

FIGURE 6-11. CRANKCASE BREATHER

## LUBRICATION SYSTEM

A full pressure oil lubrication system with a full flow, spin-on filter is used. See *Engine-Block Assembly* for service of the internal parts of the system. A low oil pressure cutout switch shuts down the engine if a low oil pressure fault occurs. The fault reset button in the control panel has to be reset to restore operation.

**Recommended Oil:** Use high quality oil with the API designation SF/CD and SAE viscosity grade suitable for the ambient temperature as listed below. Do not mix different brands of oil, which may not be compatible.

### OIL VISCOSITY VS TEMPERATURE

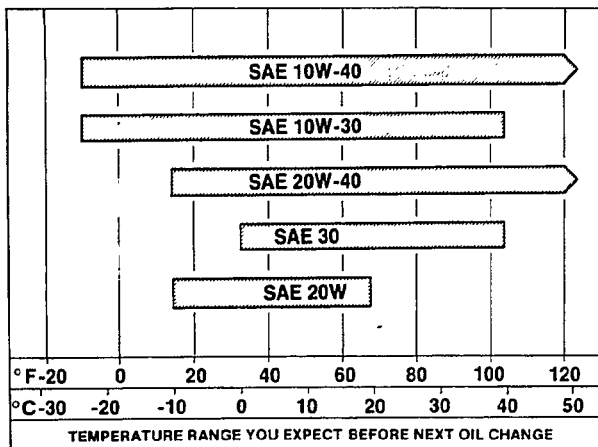

LS-1172-1

**Oil Change:** Always run the engine until it reaches the normal operating temperature before draining the oil. Hot oil drains easier and carries more contaminants with it. When completely drained, close the oil drain cock and refill with new oil.

**⚠ WARNING** *Hot crankcase oil can cause burns. Be careful not to spill or splash the waste oil.*

**Oil Filter Change:** Spin off the old filter and discard it. Apply a film of oil on the new filter gasket and spin it on until the gasket just touches the block. Then turn the filter one half turn more. Check for leaks after oil has been filled and the engine is running. Turn the filter only enough to stop leaks.

## FUEL SYSTEM

The fuel system consists of the resonator, flame arrestor, choke, carburetor, intake manifold, fuel filter and fuel pump. The carburetor mixes the air and gasoline in the correct proportion. The governor operates the throttle in the carburetor to maintain engine speed (frequency) as the load varies.

**⚠ WARNING** *Gasoline is highly flammable. Do not smoke near gasoline tanks or equipment and keep flames, sparks, pilot flames, electrical arcs and other sources of ignition well away.*

*Service and installation of fuel systems must be performed by qualified persons according to the applicable codes and standards for marine fuel systems.*

### Governor and Carburetor Adjustments

Careful adjustments of the carburetor and governor are essential for top performance. Perform all necessary engine and generator maintenance and repair before making these adjustments.

These adjustments require the use of meters to measure voltage, frequency and amperage and a stepped load bank of at least 8 kW, where a portion of at least 600 watts is variable. Digital meters are recommended. Accuracy should be at least 0.3 percent for frequency measurement and 0.5 percent for voltage measurement.

It is recommended that the set be disconnected from the AC service panel of the vessel. If the set is not disconnected, disconnect or unplug all voltage and frequency sensitive devices throughout the vessel to protect them from the variations in frequency and voltage that occur during these adjustments.

**⚠ WARNING** *Disconnect or unplug all voltage and frequency sensitive devices such as TV's, VCR's, computers and other solid-state electronic devices before making governor and carburetor adjustments. Typically, some internal circuits are powered when these types of devices are plugged in, even if the device has been switched "OFF". These circuits can be damaged by variations in voltage and frequency.*

*Consequential damage to TV's, VCR's, computers and other voltage and frequency sensitive devices as a result of failing to observe this precaution is not covered under the Onan warranty policy.*



**Note:** The following groups of adjustments must be performed in sequence.

**Governor Rod Length Adjustment:** The length of the governor rod must be checked and adjusted as follows (see Figure 6-12):

1. Loosen the lock nut at the ball joint end of the governor rod and unsnap the socket from the ball.
2. Push the governor rod gently towards the carburetor (full-throttle position). While keeping it there, turn the socket, as necessary, to lengthen or shorten the rod so that the ball and socket line up.

**CAUTION** Too much pressure on the rod can result in a faulty adjustment of the rod length.

3. Snap the socket back over the ball.
4. Tighten the lock nut while holding the socket square with the axis of the ball. Also, the crook at the at the throttle end of the rod must be kept level.
5. Gently rotate the governor arm and check for binding. If necessary, loosen the locknut and repeat Step 4 until the linkage moves smoothly. Binding can cause erratic governor action.

**Idle Speed Stop Adjustment:** The frequency specifications for 60 Hertz sets are followed in parentheses by the specifications for 50 Hertz sets.

1. If the carburetor has been overhauled, gently turn the idle and main fuel mixture screws in by hand until they seat. Then turn the idle mixture screw out one turn and the main fuel mixture screw out one and one-quarter turns so that the engine will start and run.

**CAUTION** Forcing a mixture adjustment screw in tight will score the needle and seat. Turn it in lightly by hand only.

2. Start the set and let it warm up for ten minutes under 1/2 to 3/4 rated load. Load is the product of amps and volts:

$$\text{Load (Watts)} = \text{Volts} \times \text{Amps.}$$

3. Disconnect the load (check for zero amps). Then turn the governor speed adjusting screw to obtain a frequency of 50 Hertz (40 Hertz). Turn the idle speed stop screw, if necessary, so that it does not touch the tang on the throttle lever.
4. Then turn the idle speed stop screw to obtain a frequency of 55 Hertz (45 Hertz).
5. Finally, turn the governor speed adjustment nut to obtain a no-load frequency of 62 to 63 Hertz (51.5 to 52.5 Hertz).

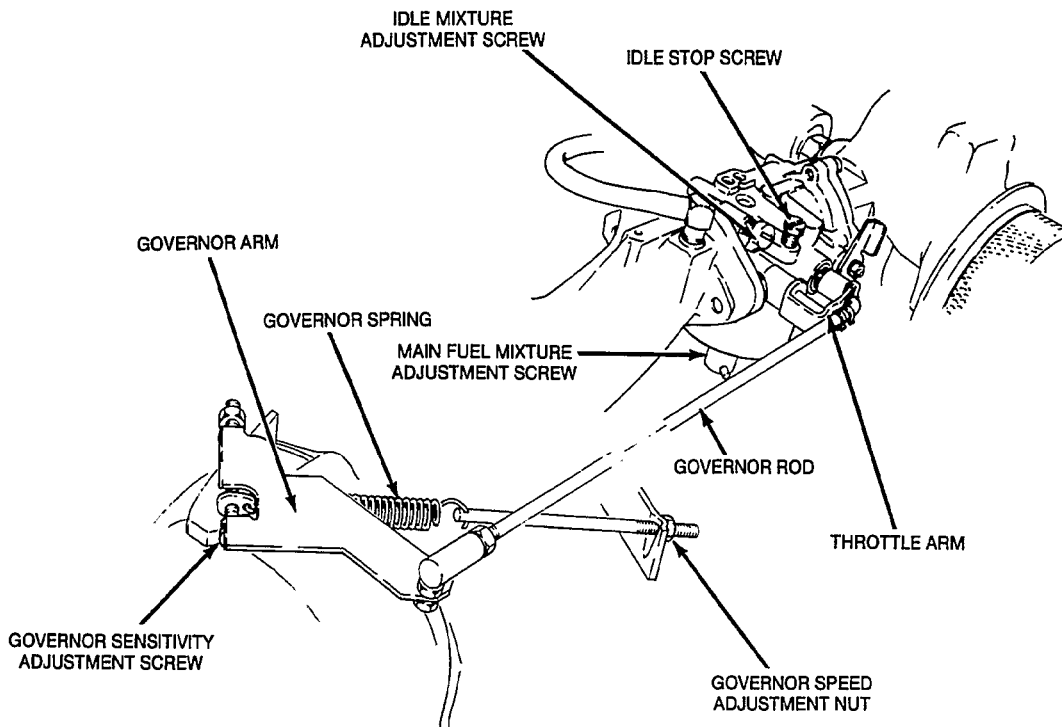

FS-1824

FIGURE 6-12. GOVERNOR/CARBURETOR LINKAGE AND ADJUSTMENTS

**Idle Mixture and Frequency Adjustments:** The frequency specifications for 60 Hertz sets are followed in parentheses by the specifications for 50 Hertz sets.

1. Disconnect all loads (check for zero amps). Then check no-load frequency. If necessary, turn the governor speed adjustment nut to obtain a no-load frequency of 62 to 63 Hertz (51.5 to 52.5 Hertz).
2. Turn the idle mixture adjustment screw clockwise until the frequency drops and then counterclockwise until it drops again. Adjust it to obtain the highest possible stable frequency. Some "wander" is normal.
3. If no-load frequency has changed because of idle mixture adjustment, repeat Steps 3, 4 and 5 under Idle Speed Stop Adjustment.
4. Check output voltage. Output voltage should be 123 to 132 VAC at 63 Hertz or 105 to 115 VAC at 52 Hertz. See *Section 8. Generator* if output voltage is not within specifications.
5. See Troubleshooting in this section if the engine runs roughly.
6. Push the adjustment limiter cap on over the mixture screw head such that it will allow equal adjustment in either direction.

**Main Fuel Mixture and Droop Adjustments:** The frequency specifications for 60 Hertz sets are followed in parentheses by the specifications for 50 Hertz sets.

1. Connect rated load. Note that output voltage falls slightly as load is increased (amps increase). Keep adjusting and recalculating the load, using the latest voltage and amperage readings, until rated load is obtained.
2. Turn the main fuel mixture adjustment screw clockwise until the frequency drops and then counterclockwise until it drops again. Adjust it to obtain the highest possible stable frequency.
3. Disconnect the load and readjust the governor speed adjustment nut to return no-load frequency to 62 to 63 Hertz (51.5 to 52.5 Hertz).

#### 4. Reconnect rated load.

- A. If droop (from no-load frequency) is more than 3 Hertz (2.5 Hertz), turn the governor sensitivity screw one turn counterclockwise. Disconnect the load and, if necessary, readjust the governor speed adjustment nut to return no-load frequency to 62 to 63 Hertz (51.5 to 52.5 Hertz). Check droop again and repeat the adjustments, if necessary.
  - B. If droop (from no-load frequency) is less than 2 Hertz (1.5 Hertz), turn the governor sensitivity screw one turn clockwise. Disconnect the load and, if necessary, readjust the governor speed adjustment nut to return no-load frequency to 62 to 63 Hertz (51.5 to 52.5 Hertz). Check droop again and repeat the adjustments, if necessary.
5. Also check governor response under 1/4, 1/2 and 3/4 rated loads. If the set hunts, increase droop to a maximum of 4 Hertz (4 Hertz). See Troubleshooting in this section if hunting is unacceptable.
  6. Push the adjustment limiter cap on over the mixture screw head such that the cap pointer indicates the current altitude.

### Carburetor Overhaul

Problems not corrected by mixture or governor adjustments are often caused by gummed-up fuel passages or worn internal parts. The most effective remedy is a complete carburetor overhaul or replacement.

Overhauling a carburetor consists of complete disassembly, thorough cleaning, and replacement of worn parts. Carburetor repair kits include new gaskets and parts subject to the most wear.

Carefully note the position of parts while removing them to make reassembly easier. Read and understand these procedures before beginning. Figure 6-13 is an exploded view of the carburetor and its parts.

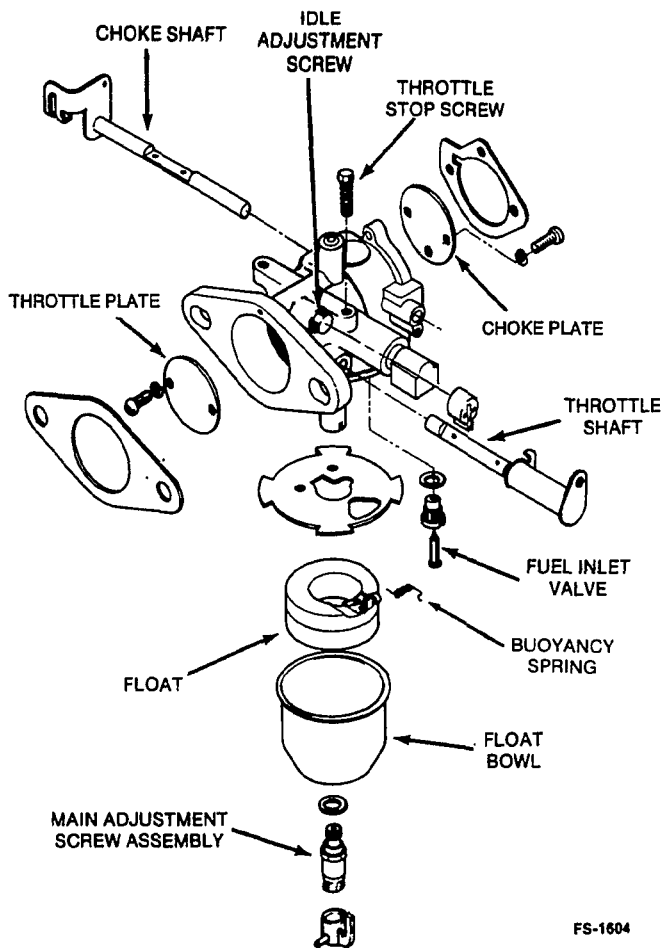

FS-1604

FIGURE 6-13. CARBURETOR

**Carburetor Disassembly:**

1. Disconnect the fuel line, governor rod, crankcase breather tube, vacuum line to the pull-off diaphragm, vacuum line to the carburetor adapter fuel overflow well and wires to the choke. Unbolt the carburetor assembly from the intake manifold.
2. Disconnect the choke links and remove the carburetor adapter from the carburetor.
3. Remove the throttle and choke plate retaining screws, and carefully pull out the throttle and choke shafts.
4. Remove the main and idle mixture screws.
5. Separate the fuel bowl from the upper section of the carburetor.
6. Carefully note the position of the float assembly parts before sliding out the retaining pin.

7. Unscrew the needle valve seat.

**Carburetor Cleaning and Repair:**

1. Use carburetor cleaning solution to clean all metal parts not replaced by parts in the repair kit. Do not soak rubber or plastic parts in cleaning solution. Follow the cleaner manufacturer's recommendations.

**CAUTION** Most parts cleaning solutions are flammable. Follow the manufacturer's recommendations.

2. Clean carbon from the carburetor bore, especially where the throttle and choke plates seat. Be careful not to plug the idle or main fuel ports.
3. Blow out all passages with compressed air. Do not use wire or other objects for cleaning passages, since they can damage critical passages.
4. Always replace the needle valve with the valve in the kit. Replace the float if it is damaged or loaded with fuel.
5. Replace the throttle and choke shafts if they are worn and fit loosely.

**Reassembly and Installation:**

1. Slide in the throttle shaft and install the throttle plate using new screws from the kit. Before tightening the screws, the plate must be centered in the bore. To do this, back off the throttle stop screw if necessary, and completely close the throttle lever. Seat the plate by gently tapping it with a small screwdriver, then tighten the screws. Install the choke shaft and plate in the same manner.
2. Install the idle mixture screw assembly. Turn the screw in by hand until lightly seated, then turn it out one turn.

**CAUTION** Forcing the mixture adjustment screw tight will score the needle and seat. Turn in the screw by hand until lightly seated.

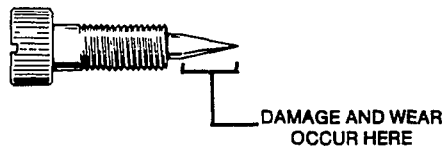

FS-1483-3

FIGURE 6-14. MIXTURE SCREW INSPECTION

3. Install the needle valve and seat, fuel bowl gasket, and float assembly. Make sure all clips and springs are properly placed, and that the float moves freely without binding (Figure 6-15).

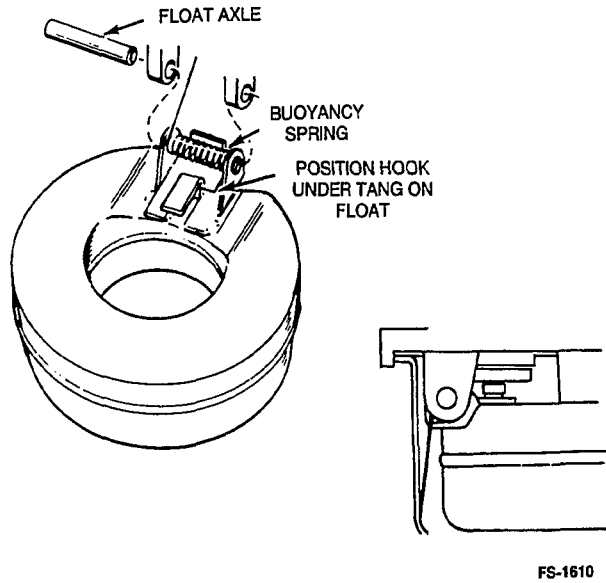

FIGURE 6-15. FLOAT INSTALLATION

4. Turn the float and needle valve assembly upside down and check the float level as shown by Figure 6-16. The full weight of the float should rest on the needle valve and spring while making the measurement. If necessary, remove the float and bend the tab at the location indicated to adjust the float level.

**CAUTION** *The needle valve and seat can be damaged by pressing down on the float. Remove the float to bend the tab when adjusting the float level.*

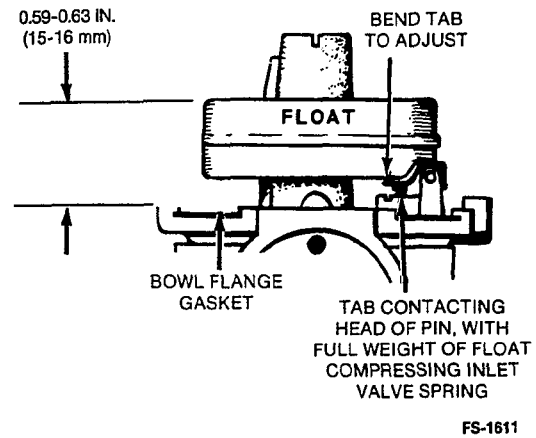

FIGURE 6-16. FLOAT ADJUSTMENT

5. Install the float bowl and the main mixture screw assembly. Turn the screw in by hand until lightly seated, then turn it out 1-1/4 turns.

**CAUTION** *Forcing the mixture adjustment screw tight will score the needle and seat. Turn in the screw by hand until lightly seated.*

6. Reinstall the carburetor and adjust it according to Governor/Carburetor Adjustments.

## Choke Assembly

The choke assembly consists of the choke plate, shaft, linkage, bi-metal coil/electric heater assembly and pull-off diaphragm. The bi-metal coil shaft is linked to the choke shaft, and holds the choke plate nearly closed when the engine is cold. Fuel is pulled into the carburetor venturi by the vacuum created because of the closed choke, even while cranking a cold engine. As the engine starts up, intake manifold vacuum causes the pull-off diaphragm to pull in and partially open the choke. As the engine continues to run, the electric heater causes the bi-metal to turn its shaft to open the choke.

**CAUTION** *A hot choke cover can cause burns. Do not touch it while engine is running.*

If the engine starts but runs roughly and blows out black smoke after a minute or two of operation, the choke is set for too rich a mixture. If the engine starts but sputters or stops before it warms up, the choke is set for too lean a mixture.

**Choke Adjustment:** Table 6-1 lists choke settings for various ambient temperatures. Stop the set and allow it to cool before making adjustments.

**TABLE 6-1. CHOKE ADJUSTMENTS**

Ambient Air Temperature	Rotation From Reference Mark*
40°F (4°C)	0°
45°F (7°C)	4° CW
50°F (10°C)	8° CW
55°F (13°C)	12° CW
60°F (16°C)	16° CW
65°F (18°C)	20° CW
70°F (21°C)	24° CW
75°F (24°C)	27° CW
80°F (27°C)	32° CW
85°F (29°C)	35° CW
90°F (32°C)	39° CW
95°F (35°C)	43° CW
100°F (38°C)	47° CW

\* Each mark on choke housing equals 5° angular rotation.

1. Remove the plastic cover from the bi-metal coil/electric heater assembly (Figure 6-17).

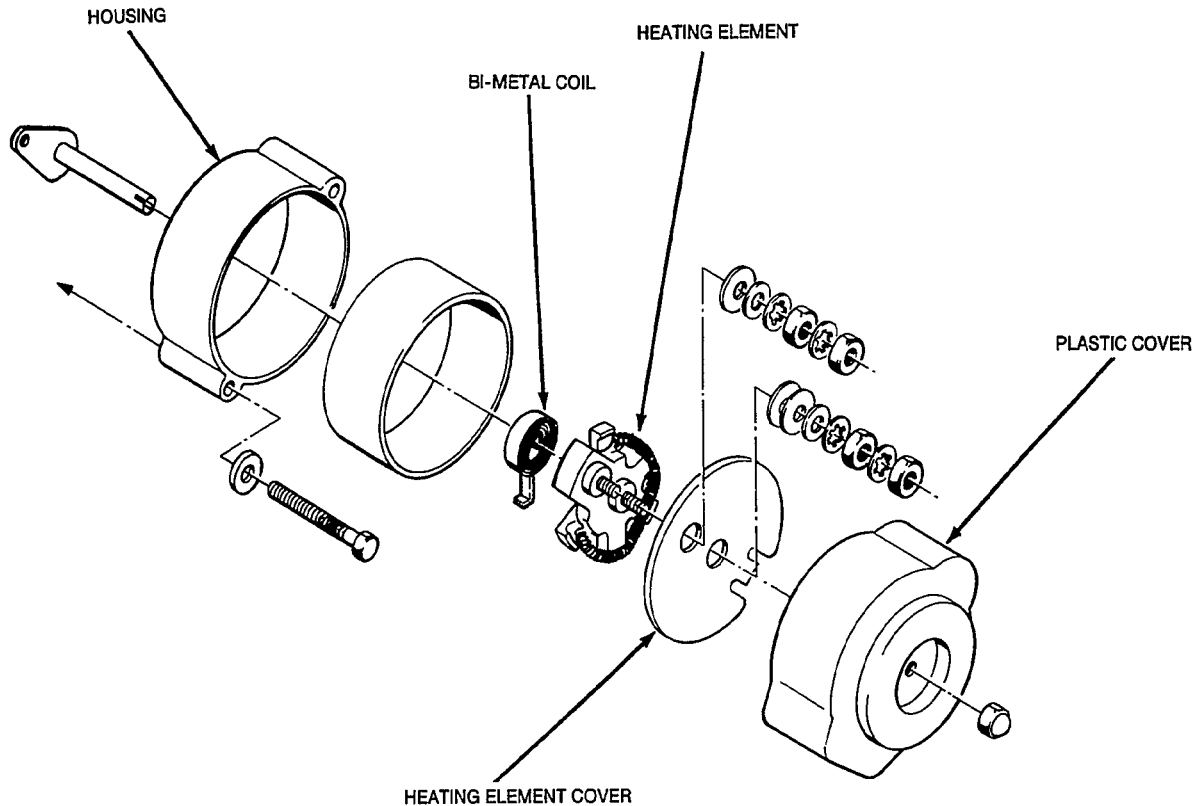

FS-1605

**FIGURE 6-17. CHOKE BI-METAL COIL/ELECTRIC HEATER ASSEMBLY**

2. Move the choke lever back and forth to check for smooth operation. The lever should return automatically, without sticking, to the free position when released from the open position.
3. Loosen the heater element cover screws and rotate the heating element until the choke plate is halfway open.
4. Slowly rotate the heater cover counterclockwise while tapping the carburetor choke lever, making it bounce. Continue rotation until tapping the choke lever no longer makes it bounce. This is the fully-closed, reference position.
5. Determine from Table 6-1 the number of degrees the heater cover must be rotated clockwise from the reference position, and then lock the cover in place with the mounting screws.
6. Replace the plastic cover.

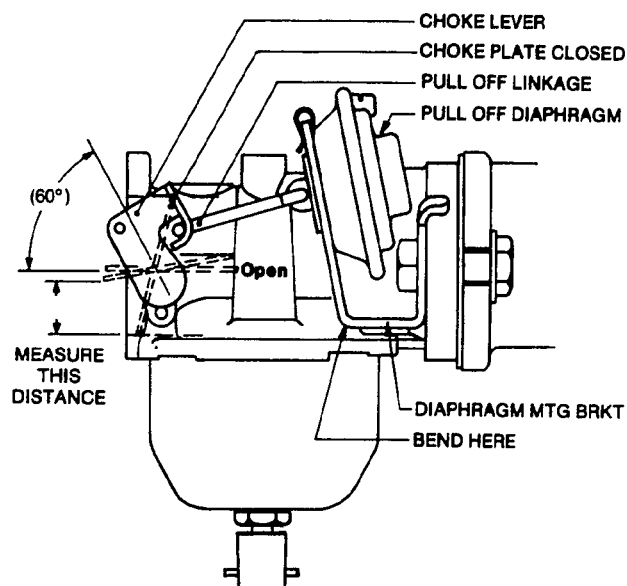

FS-1803 -1

FIGURE 6-18. CHOKE PULL-OFF DIAPHRAGM

### **Choke Bi-Metal/Heater Assembly Replacement:**

If the choke fails to open, remove the plastic cover from the bi-metal/heater assembly and check if the heater element becomes hot after a few minutes of operation. If the element does not get hot, check for voltage (approximately 20 VAC) at the heater terminals. If there is no voltage, check for opens or shorts in the control wiring.

If there is voltage, replace the defective heater assembly. Also, inspect the bi-metal coil and replace it if it appears warped and rubs inside the housing. Install the bi-metal coil with the foot of the leg pointed clockwise (Figure 6-17). Also, make sure that the leg engages the slotted tang in the heater cover, and that the inner crook engages the slot in the shaft.

**Choke Pull-Off Diaphragm:** The choke pull-off diaphragm partially opens the choke plate when the engine starts up, for smoother operation while the engine warms up (Figure 6-18). Replace the pulloff diaphragm assembly if it does not pull in when the engine starts up. If it functions, check operation as follows:

1. Remove the flame arrestor/resonator assembly from the carburetor for access to the choke plate.
2. Disconnect the diaphragm hose from the intake manifold and apply a vacuum of 4-18 inches (102-457 mm) Hg to the hose to pull in the diaphragm for the following checks.
3. Check and correct alignment (as seen from above) of the diaphragm stem, pull off link and slot in the choke lever.
4. Apply light pressure to the choke lever to take up freeplay in the linkage and measure the distance indicated in Figure 6-18. Bend the diaphragm mounting bracket at the point shown, if necessary, to obtain a distance of 0.39-0.43 inches (9.9-10.9 mm).
5. Check for free movement by moving the choke lever back and forth.

## Fuel Filter

A disposable fuel filter is connected at the fuel inlet of the carburetor. Replace the filter if it is clogged.

## Fuel Pump

An electric fuel pump is used to lift gasoline to the carburetor from the fuel tank. Replace the pump if it malfunctions or cannot develop a pressure of at least 3.5 PSIG (17.2 kPa).

**WARNING** *Automotive electric fuel pumps develop high pressures that can cause engine flooding and the possibility of fire. Always replace the pump with the correct Onan-supplied pump.*

## ELECTRIC STARTER

The starter is a 12 Volt, negative ground motor with permanent magnets and an inertial engagement pinion (Figure 6-19).

**CAUTION** *This starter complies with U.S.C.G. ignition protection requirements. To maintain compliance, the starter must be assembled correctly with the right parts.*

### Removal and Disassembly:

1. Disconnect the negative (-) cable from the battery.
2. Disconnect the starter cable.
3. Remove the two starter mounting bolts and remove the starter.
4. Remove the two starter through-bolts and separate the brush end cap, housing and armature assemblies.
5. Remove the roll pin to disassemble the pinion assembly from the armature shaft.

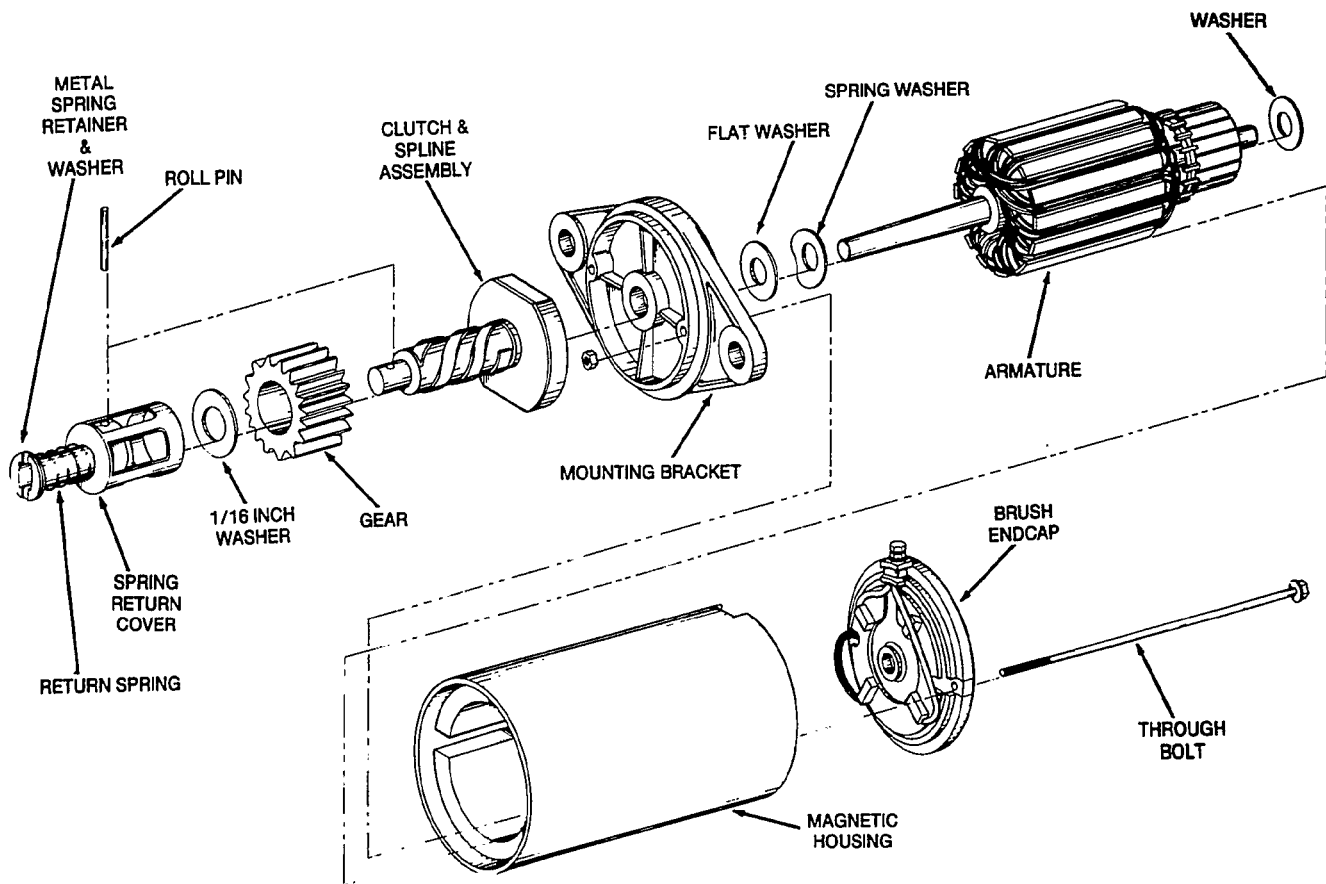

ES-1613

FIGURE 6-19. ELECTRIC STARTER ASSEMBLY

**Testing for Grounded Armature Windings:** Use an insulation resistance meter to measure the resistance between any commutator bar and the armature shaft or laminations (Figure 6-20). Replace the starter if the insulation resistance is less than 100,000 ohms.

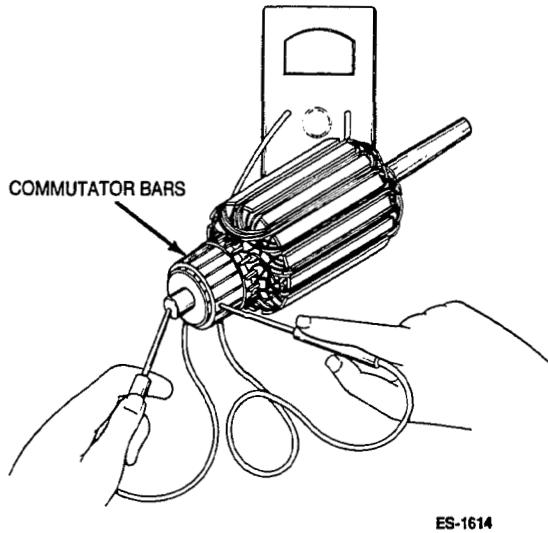

**FIGURE 6-20. TESTING FOR GROUNDED ARMATURE WINDINGS**

**Testing for Open Armature Windings:** Use an ohmmeter to measure winding resistance. Touch one test probe to a commutator bar while touching the other probe to each other commutator bar in turn (Figure 6-22). Replace the starter if an open winding is indicated (high resistance).

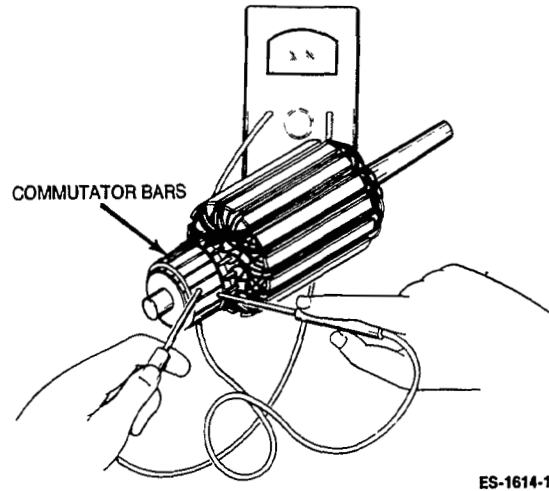

**FIGURE 6-22. TESTING FOR OPEN ARMATURE WINDINGS**

**Testing for Shorted Armature Windings:** Use a growler to locate shorts in the armature windings (Figure 6-21). Place the armature in the growler and hold a thin steel blade (hacksaw blade) parallel to the core and about 1/2 inch (12 mm) from it while moving the blade from one pole of the growler to the other. Rotate the armature in the growler one slot over and keep on repeating the test until the armature is back to the original position. Shorted armature windings will vibrate the blade and pull it to the core. Replace the starter if the armature windings are shorted.

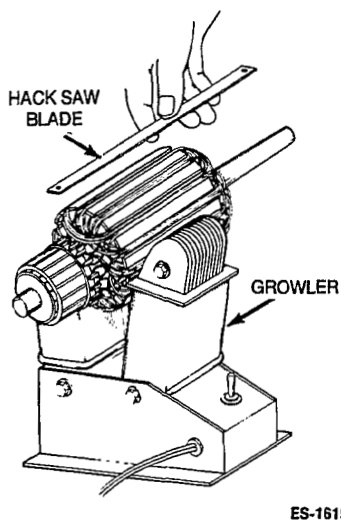

**FIGURE 6-21. TESTING FOR SHORTED ARMATURE WINDINGS**

**Armature Service:** If the armature windings are good, and the permanent magnets in the housing are not loose or cracked, turn the commutator in a lathe. Remove only enough metal to clean up pits and out-of-roundness. Undercut the mica between bars 1/32 inch (0.8 mm).

**Brushes:** Replace the brush end cap and brushes as an assembly if brushes are worn to a length of 0.425 inches (11 mm) or less.

**Assembly:** Assembly is the reverse of disassembly. Torque the motor through bolts to 40 in-lbs (4.5 Nm), and the motor mounting bolts to 30 ft-lbs (41 Nm). Grease the pinion helix spline lightly with GE Versilube 322-L.



## TROUBLESHOOTING ENGINE PRIMARY SYSTEMS

**▲WARNING** *Many troubleshooting procedures present hazards which can result in severe personal injury or death. Only qualified service personnel with knowledge of fuels, electricity, and machinery hazards should perform service procedures. Review safety precautions on inside cover page.*

Trouble	Possible Cause	Corrective Action
Engine Misfires	<ol style="list-style-type: none"> <li>1. Faulty ignition due to:                             <ol style="list-style-type: none"> <li>A. Worn or fouled spark plugs.</li> <li>B. Faulty ignition coil.</li> <li>C. Faulty plug wires.</li> <li>D. Faulty ignition module.</li> </ol> </li> <li>2. Lean fuel mixture due to:                             <ol style="list-style-type: none"> <li>A. Incorrectly adjusted fuel mixture screws.</li> <li>B. Incorrect float level.</li> <li>C. Dirt in carburetor.</li> <li>D. Vacuum leak.</li> </ol> </li> <li>3. Contaminated fuel.</li> </ol>	<ol style="list-style-type: none"> <li>1.                             <ol style="list-style-type: none"> <li>A. Replace spark plugs.</li> <li>B. Test coil and replace if faulty.</li> <li>C. Test spark plug wires and replace if faulty.</li> <li>D. Test ignition module and replace if faulty.</li> </ol> </li> <li>2.                             <ol style="list-style-type: none"> <li>A. Adjust carburetor main and idle adjustment screws.</li> <li>B. Adjust carburetor float level</li> <li>C. Disassemble carburetor and clean all internal passages.</li> <li>D. Locate leak and correct as required.</li> </ol> </li> <li>3. Drain fuel tank and refill with fresh fuel.</li> </ol>
Engine Backfires	<ol style="list-style-type: none"> <li>1. Faulty ignition due to:                             <ol style="list-style-type: none"> <li>A. Incorrect ignition timing.</li> <li>B. Incorrect spark plug gap.</li> </ol> </li> <li>2. Lean fuel mixture due to:                             <ol style="list-style-type: none"> <li>A. Incorrectly adjusted fuel mixture screws</li> <li>B. Incorrect float level.</li> <li>C. Dirt in carburetor.</li> </ol> </li> <li>3. Mechanical damage to engine.</li> </ol>	<ol style="list-style-type: none"> <li>1.                             <ol style="list-style-type: none"> <li>A. Check timing. Replace magnetic trigger ring if out of limits.</li> <li>B. Reset spark plug gap.</li> </ol> </li> <li>2.                             <ol style="list-style-type: none"> <li>A. Adjust carburetor main and idle adjustment screws.</li> <li>B. Adjust carburetor float level.</li> <li>C. Disassemble carburetor and clean all internal passages.</li> </ol> </li> <li>3. See <i>Section 9. Engine-Block Assembly</i>.</li> </ol>
Engine Lacks Power	<ol style="list-style-type: none"> <li>1. Faulty ignition due to:                             <ol style="list-style-type: none"> <li>A. Incorrect ignition timing.</li> <li>B. Incorrect spark plug gap.</li> </ol> </li> <li>2. Restricted fuel flow due to:                             <ol style="list-style-type: none"> <li>A. Plugged fuel filter.</li> <li>B. Faulty fuel pump.</li> </ol> </li> <li>3. Incorrect fuel mixture due to:                             <ol style="list-style-type: none"> <li>A. Incorrectly adjusted fuel mixture screws</li> <li>B. Incorrect float level</li> <li>C. Dirt in carburetor.</li> </ol> </li> <li>4. Exhaust system blocked or restricted.</li> <li>5. Incorrect valve clearance.</li> <li>6. Excessive engine wear or damage to engine.</li> </ol>	<ol style="list-style-type: none"> <li>1.                             <ol style="list-style-type: none"> <li>A. Check timing. Replace magnetic trigger ring if out of limits.</li> <li>B. Reset spark plug gap.</li> </ol> </li> <li>2.                             <ol style="list-style-type: none"> <li>A. Replace fuel filter.</li> <li>B. Test fuel pump and replace if faulty.</li> </ol> </li> <li>3.                             <ol style="list-style-type: none"> <li>A. Adjust carburetor main and idle adjustment screws.</li> <li>B. Adjust carburetor float level.</li> <li>C. Disassemble carburetor and clean all internal passages.</li> </ol> </li> <li>4. Locate and remove cause of blockage.</li> <li>5. Adjust valve clearance. See <i>Section 9. Engine-Block Assembly</i></li> <li>6. See <i>Section 9. Engine-Block Assembly</i></li> </ol>

Trouble	Possible Cause	Corrective Action
Engine Overheats	<ol style="list-style-type: none"> <li>1. Restricted compartment ventilation.</li> <li>2. Lean fuel mixture due to:               <ol style="list-style-type: none"> <li>A. Incorrectly adjusted fuel mixture screws.</li> <li>B. Incorrect float level.</li> <li>C. Dirt in carburetor.</li> </ol> </li> <li>3. Defective coolant or sea water pump, or impeller.</li> <li>4. Clogged coolant passages.</li> </ol>	<ol style="list-style-type: none"> <li>1. Clear away any debris that may restrict airflow to set. Do not use compartment for storage.</li> <li>2.               <ol style="list-style-type: none"> <li>A. Adjust carburetor main and idle adjustment screws.</li> <li>B. Adjust carburetor float level</li> <li>C. Disassemble carburetor and clean all internal passages.</li> </ol> </li> <li>3. Check pump flow rates and replace defective parts.</li> <li>4. Flush out cooling system.</li> </ol>
Black Exhaust	<ol style="list-style-type: none"> <li>1. Rich fuel mixture due to:               <ol style="list-style-type: none"> <li>A. Choke incorrectly adjusted or sticking</li> <li>B. Incorrectly adjusted carburetor.</li> </ol> </li> </ol>	<ol style="list-style-type: none"> <li>1.               <ol style="list-style-type: none"> <li>A. Clean and adjust choke.</li> <li>B. Adjust carburetor idle and main adjustment screws.</li> </ol> </li> </ol>
Engine Hunts or Surges	<ol style="list-style-type: none"> <li>1. Sticking or binding governor linkage.</li> <li>2. Incorrect governor adjustment.</li> <li>3. Incorrect fuel mixture due to:               <ol style="list-style-type: none"> <li>A. Incorrectly adjusted fuel mixture screws.</li> <li>B. Incorrect float level.</li> <li>C. Dirt in carburetor.</li> </ol> </li> </ol>	<ol style="list-style-type: none"> <li>1. Clean or replace governor linkage.</li> <li>2. Adjust governor speed and sensitivity.</li> <li>3.               <ol style="list-style-type: none"> <li>A. Adjust carburetor main and idle adjustment screws.</li> <li>B. Adjust carburetor float level.</li> <li>C. Disassemble carburetor and clean all internal passages.</li> </ol> </li> </ol>
High Oil Consumption (Note: New engines sometimes have high oil consumption during break-in)	<ol style="list-style-type: none"> <li>1. Oil viscosity too light or oil is diluted.</li> <li>2. Crankcase breather valve is dirty or defective.</li> <li>3. Oil leaks.</li> <li>4. Excessive engine wear.</li> <li>5. Light loading.</li> </ol>	<ol style="list-style-type: none"> <li>1. Drain oil and refill with correct viscosity oil.</li> <li>2. Replace breather valve and replace if defective.</li> <li>3. Locate source of leak and repair as required.</li> <li>4. See <i>Section 9. Engine-Block Assembly</i></li> <li>5. Don't run set at no load for long periods of time.</li> </ol>
Low Oil Pressure	<ol style="list-style-type: none"> <li>1. Oil viscosity too light or oil is diluted.</li> <li>2. Low oil level.</li> <li>3. Faulty oil bypass valve.</li> <li>4. Excessive engine wear or defective oil pump.</li> </ol>	<ol style="list-style-type: none"> <li>1. Drain oil and refill with correct viscosity oil.</li> <li>2. Add oil as required.</li> <li>3. Inspect oil bypass valve and clean or replace as required See <i>Section 9. Engine-Block Assembly</i></li> <li>4. See <i>Section 9 - Engine Block Assembly</i></li> </ol>

# Section 7. Control System

## GENERAL

The control system starts and stops the set on command, disconnects the starter motor, recharges the starting battery, flashes the generator field on each start up, records accumulated running time and shuts down the engine if low oil pressure, high engine temperature or high exhaust temperature occurs. It is powered by the 12 V starting battery. Use the troubleshooting guide at the end of this section to locate problems related to the control system.

## COMPONENTS

Figure 7-1 illustrates the layout of the control system components.

The control system may also include an optional remote control panel with a three-wire, B+ switching Start-Stop switch, accumulated running time meter, engine running light and battery condition meter. Or, it may include a deluxe version with a Start-Stop switch, engine running light and meters to indicate accumulated running time, oil pressure, coolant temperature and battery voltage.

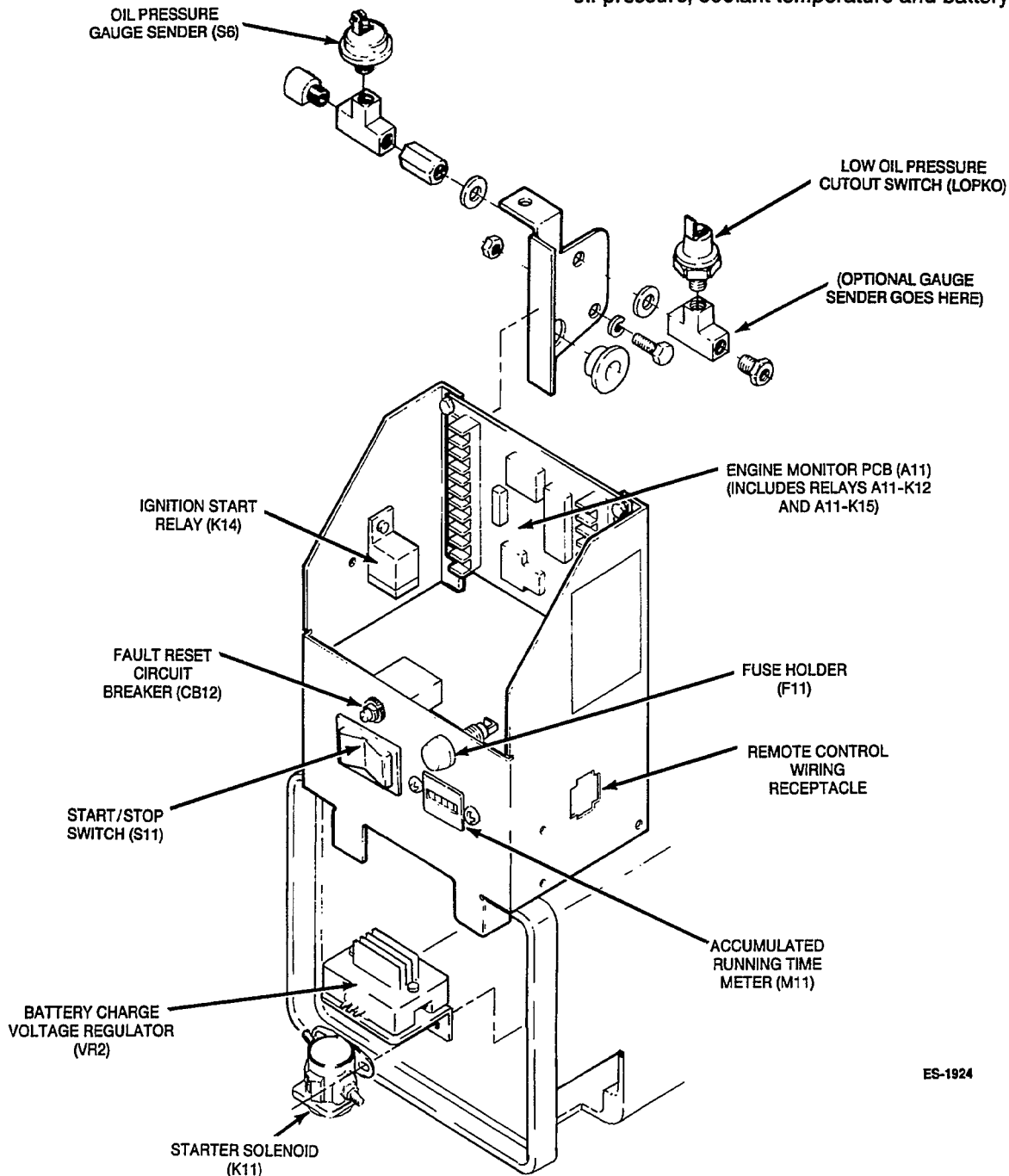

FIGURE 7-1. CONTROL COMPONENTS

## SEQUENCE OF OPERATION

Refer to Figure 7-2, the wiring schematic, while working through the following sequence of operation. Refer to the DC control wiring diagram that should be kept with the set to identify wiring connections between components.

1. Holding the Start-Stop switch (S11) in the Start position causes relays K11 (starter solenoid) and K14 (ignition start) to pull in.
2. Relay K14 connects the ignition coil (T1), fuel pump (E5) and coolant pump (E7) to the battery (BT1).
3. Relay K11 connects the starter motor (B1) and the generator (G1) field to the battery. The engine should start right away. Flashing the generator field with the battery assures rapid build-up of generator output voltage. A diode (CR1) protects the battery from excitation voltages that build up before the battery is disconnected.
4. Generator voltage builds up as the set accelerates to governed speed. Relay A11-K15 on the engine monitor PCB (Printed Circuit Board) pulls in when generator voltage reaches approximately 90 volts.
5. Relay A11-15 disconnects Relay K11, which drops out, disconnecting the starter motor and generator field from the battery, even if the Start switch is still being held in by hand.
6. Two sets of Relay A11-K15 contacts also close.
  - One set of contacts cause Power Relay A11-K12 (on the engine monitor PCB) to pull in by completing the circuit through the Relay K11 coil. The current is enough to pull in, and hold in, the Relay A11-K12 coil, but is not enough to activate Relay K11, which is relatively large.
  - The other set of contacts connects the low oil pressure (S1) and high engine temperature (S2) cutout switches into the engine safety shutdown circuit. By the time the relay connects the switches, oil pressure should have built up to normal, opening S1, and temperatures in a hot engine should have equalized, opening S2. The delay in connecting these cutout switches prevents nuisance shutdowns during startup. Resistor A11-R2 also adds delay by limiting current, which causes fault circuit breaker CB12 (Item 9 below) to respond slower.
7. Power Latch Switch S6 closes when the oil pressure reaches 5 psi, providing a ground path for Power Relay A11-K12.
8. Power Relay A11-K12 keeps the set running after the Start switch is released and relay K14 drops out. The engine running time meter (M11), optional oil pressure gauge (M12) and sender (E1), coolant temperature gauge (M13) and sender (E2), and battery voltmeter (M14) are also powered.
9. When the Stop switch is pushed in, positive (+) battery voltage is applied to the normally negative (-) side of the Relay A11-K12 coil, causing it to drop out, shutting off ignition. Resistor A11-R1 limits current so that Relay K11 will not be activated when the Stop switch is pushed in.
10. If a low oil pressure, high engine temperature or high exhaust temperature fault occurs, the appropriate cutout switch (S1, S2 or S5) will close, causing current to flow through the fault circuit breaker heater (CB12). The circuit breaker will trip, opening the relay A11-K12 coil circuit, causing it to drop out, shutting off ignition. After the circuit breaker has cooled, it can be reset at the control panel. The cause of the shutdown should be determined and service accomplished before the set is returned to service.
11. Battery charging while the set is running is provided for by a separate generator winding and electronic voltage regulator VR2. Circuit breaker CB13 protects the regulator from direct shorts to ground.
12. The battery charging windings of the generator are also connected to the choke heater (E6) to keep the choke fully open while the set is running.
13. Fuse F11 protects the control circuits.

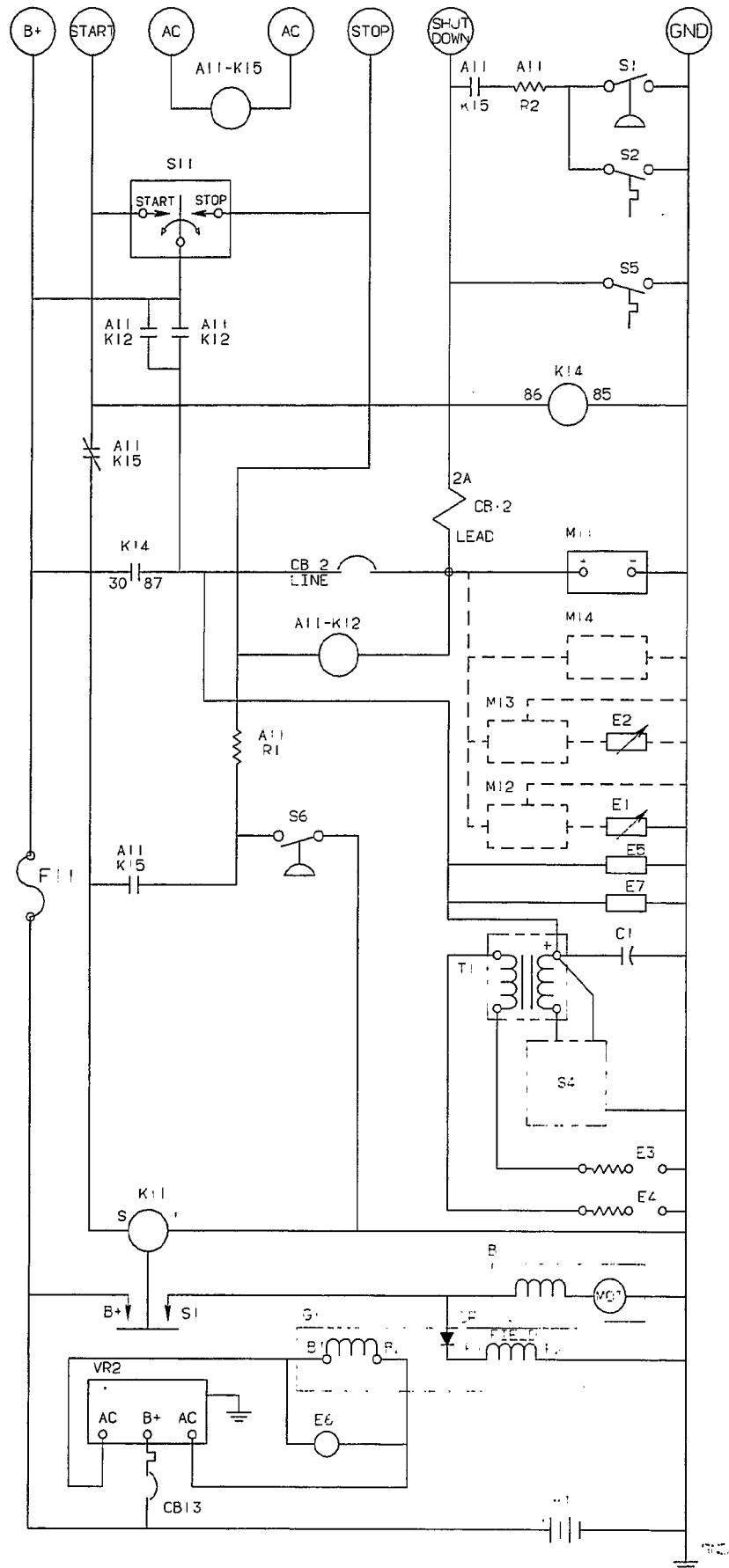

FIGURE 7-2. ENGINE CONTROL WIRING SCHEMATIC

## CONTROL TROUBLESHOOTING GUIDE



**WARNING** *Many troubleshooting procedures present hazards which can result in personal injury or death. Only qualified service personnel with knowledge of fuels, electricity, and machinery hazards should perform service procedures. Review safety precautions on inside cover page.*

Trouble	Possible Cause	Corrective Action
<p>Engine Does Not Crank</p>	<ol style="list-style-type: none"> <li>1. Control fuse F11 open.</li> <li>2. Insufficient voltage for cranking due to:               <ol style="list-style-type: none"> <li>A. Terminal connection loose or corroded.</li> <li>B. Battery dead or not charged</li> </ol> </li> <li>3. If engine cranks at set but not at the remote control panel, cause may be:               <ol style="list-style-type: none"> <li>A. Open circuit in remote control.</li> <li>B. Fault with remote start switch.</li> </ol> </li> <li>4. If engine cranks at remote control panel but not at set, cause may be:               <ol style="list-style-type: none"> <li>A. Open circuit in wiring between S11 switch and engine monitor PCB (A11).</li> <li>B. Fault in S11 switch.</li> </ol> </li> <li>5. There is voltage at terminal S, but not at S1 of starter solenoid K11 during START.</li> <li>6. There is voltage at the starter motor terminal during START.</li> <li>7. There is no voltage at terminal S of starter solenoid K11 during START.</li> </ol>	<ol style="list-style-type: none"> <li>1. Replace fuse (10 ampere)</li> <li>2.               <ol style="list-style-type: none"> <li>A. Clean and tighten connections at battery, K11 start solenoid, and the starter motor.</li> <li>B. Check condition of battery and recharge or replace.</li> </ol> </li> <li>3.               <ol style="list-style-type: none"> <li>A. Check for continuity and correct if circuit is open.</li> <li>B. Replace remote start switch.</li> </ol> </li> <li>4.               <ol style="list-style-type: none"> <li>A. Check for continuity and correct if circuit is open.</li> <li>B. Replace S11 switch.</li> </ol> </li> <li>5. Check voltage at terminal 1 of solenoid K11. If it is not "O", fix lead to ground. If voltage at terminal 1 of solenoid K11 is "O", replace faulty solenoid K11.</li> <li>6. Service or replace defective starter.</li> <li>7. Fix open circuit between K11 and engine monitor PCB (A11.) If OK, replace defective engine monitor board (A11).</li> </ol>

## CONTROL TROUBLESHOOTING GUIDE



**Many troubleshooting procedures present hazards which can result in personal injury or death. Only qualified service personnel with knowledge of fuels, electricity, and machinery hazards should perform service procedures. Review safety precautions on inside cover page.**

Trouble	Possible Cause	Corrective Action
Engine Cranks But Does Not Start	<ol style="list-style-type: none"> <li>1. Faulty ignition due to defective spark plugs, plug wires, coil, or electronic module.</li> <li>2. Faulty fuel system due to sticking choke, faulty fuel pump, plugged filter, or carburetor misadjustment.</li> <li>3. There is no voltage at igniter coil or fuel pump positive terminal.</li> </ol>	<ol style="list-style-type: none"> <li>1. Refer to <i>Ignition System</i> section for test and service procedures.</li> <li>2. Refer to <i>Fuel System</i> section for test and service procedures.</li> <li>3. Fix open circuits or replace defective ignition start Relay K14.</li> </ol>
Engine Starts But Stops When Start Switch is Released	<ol style="list-style-type: none"> <li>1. Fault condition.</li> <li>2. Defective Fault Sensor.</li> <li>3. Defective relay on engine monitor PCB (A11).</li> <li>4. Defective fault circuit breaker CB12.</li> <li>5. 90VAC not present across AC terminals of engine monitor PCB (A11) because of:               <ol style="list-style-type: none"> <li>A. Defective flash diode CR1</li> <li>B. Defective generator</li> </ol> </li> </ol>	<ol style="list-style-type: none"> <li>1. Service and repair as required.</li> <li>2. Replace sensor.</li> <li>3. Replace A11.</li> <li>4. Replace CB12.</li> <li>5.               <ol style="list-style-type: none"> <li>A. Replace diode CR1.</li> <li>B. See Section 8. <i>Generator</i>.</li> </ol> </li> </ol>
Low Battery, Generator Set Does Not Recharge	<ol style="list-style-type: none"> <li>1. Weak or discharged battery.</li> <li>2. Load connected to battery while set is turned off.</li> <li>3. Generator set not run long enough for built-in charger to recharge battery.</li> <li>4. Defective VR2 voltage regulator.</li> <li>5. Defective stator winding (B1-B2).</li> </ol>	<ol style="list-style-type: none"> <li>1. Connect a separate battery charger to bring battery up to full charge. If battery will not take charge, replace it.</li> <li>2. Turn off load.</li> <li>3. Supplement charging with a battery charger when boat is at dockside.</li> <li>4. Replace defective VR2.</li> <li>5. Refer to Section 8. <i>Generator</i> for testing and service.</li> </ol>





# Section 8. Generator

## GENERAL

The generator is of the 4-pole, revolving field design with slip rings. The generator has four output leads for single phase, 120 VAC or 120/240 VAC connections. It has auxiliary windings for battery charging.

A taper fit and rotor through bolt align and couple the rotor and engine crankshaft. The other end of the rotor is supported by a sealed, pre-lubricated ball bearing assembly.

Cooling air is pulled through the generator housing by a rotor mounted fan. The fan casting has gear teeth engaged by the starter pinion for cranking. See Figure 8-1.

Use the troubleshooting guide at the end of this section to locate problems related to the generator.

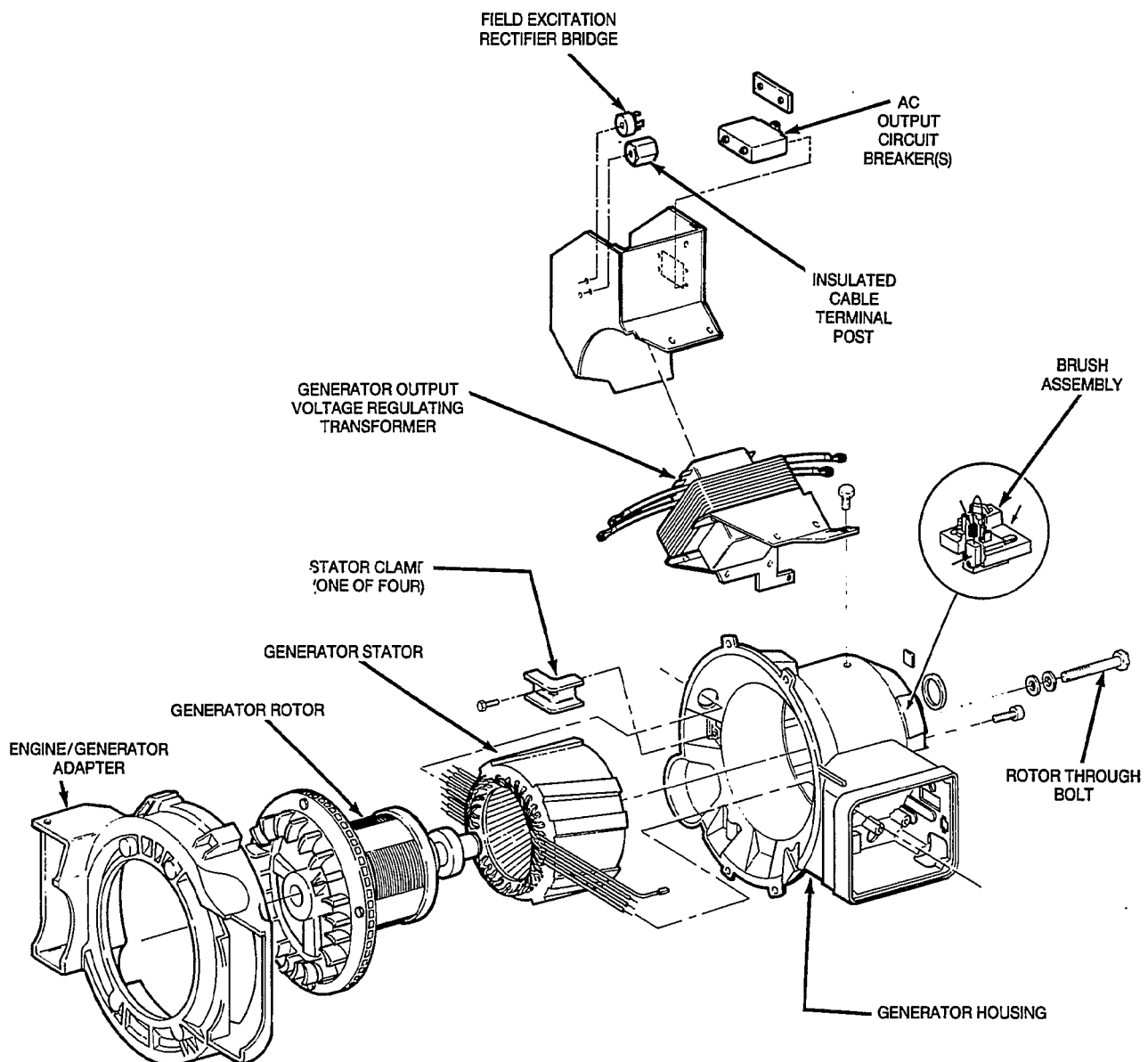

G-1235

FIGURE 8-1. GENERATOR ASSEMBLY

## PRINCIPLE OF OPERATION

Refer to Figure 8-2, the wiring schematic, while working through the following description.

1. DC is supplied to the field winding (F1 - F2 leads) through brushes and slip rings, thereby establishing a revolving, 4-pole magnetic field. The battery is connected during startup (see Control System) to initiate field excitation. The generator supplies the field current during operation through a voltage regulating transformer T21, and a full wave rectifier bridge CR21. Rated output voltage is maintained as the generator load varies by varying field current to maintain field strength proportional to the load.
2. The revolving magnetic field induces AC in the stator windings (T1 - T2 and T3 - T4) which are connected to the load.
3. The load currents pass through the primary windings (H1 - H2 and H3 - H4) of the voltage regulating transformer T21. The secondary windings of the transformer are connected in series with the bridge rectifier and stator winding T1 - T2 shunt.
4. Under light load, stator winding T1 - T2 can supply sufficient current for the field to maintain rated output voltage. Since load currents passing through regulating transformer TR21 are small at light load, the transformer has only a small effect on the current shunted for the field.
5. As the load increases, load currents passing through the transformer increase, resulting in a proportional increase of current in the secondary windings, which are connected to supply the field. Rated output voltage is thereby maintained as the load varies.

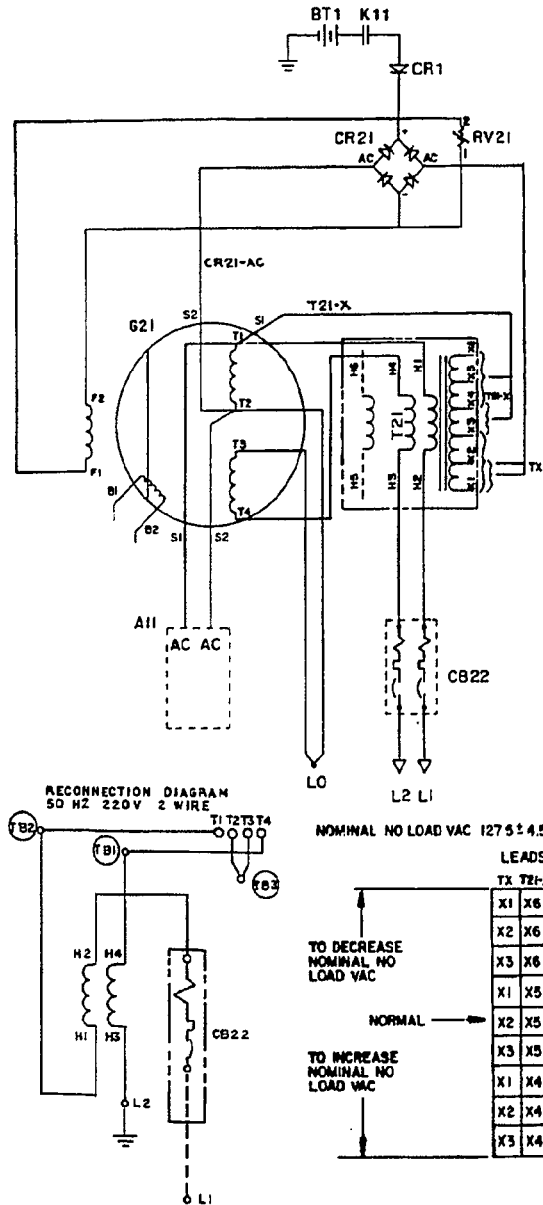

RATED VOLTAGE	NOMINAL NO LOAD VAC ± 4.5 V
120/240	127.5 (255)
110/220	110 (220)

612-6550

FIGURE 8-2. AC POWER WIRING SCHEMATIC

## GENERATOR SERVICE

Always disconnect the battery cables (negative [-] first) from the battery to prevent accidental starting of the set while servicing the generator.

**⚠ WARNING** *Accidental starting of the set while working on it can cause severe injury. To prevent accidental starting, disconnect the battery cables (negative [-] first) from the battery.*

*The negative (-) cable is always disconnected first, and connected last, to prevent arcing if a tool accidentally touches the frame or other grounded metal parts of the set while disconnecting or connecting the positive (+) cable. Arcing can ignite the explosive hydrogen gas given off by the battery, and cause severe injury.*

### Brush Replacement

Brushes can be inspected and serviced while the set is in place.

1. Remove the resonator/flame arrestor assembly.
2. Remove the access cover for the brush assembly.
3. Check the brushes for wear with a piece of wire marked off 1 inch (25 mm) from one end (Figure 8-3). Replace the brush and the spring if the wire goes into the brush holder 1 inch or more.

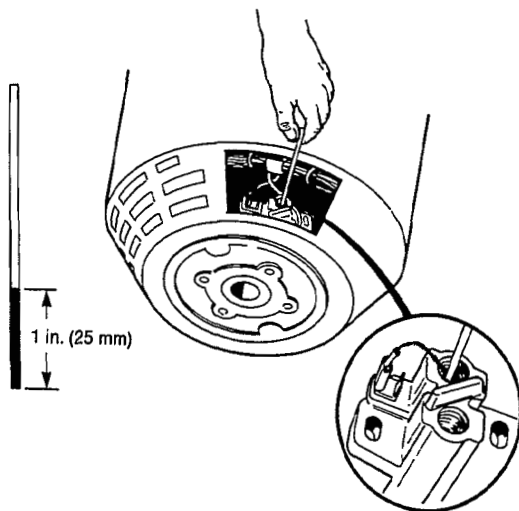

G-1174

FIGURE 8-3. CHECKING BRUSH WEAR

4. To replace brushes, remove the brush holder by disconnecting the two leads to the holder and removing the two mounting screws.

5. Install the new brushes and springs in the holder and keep them in place during assembly by inserting a piece of wire through the holder, as shown in Figure 8-4.

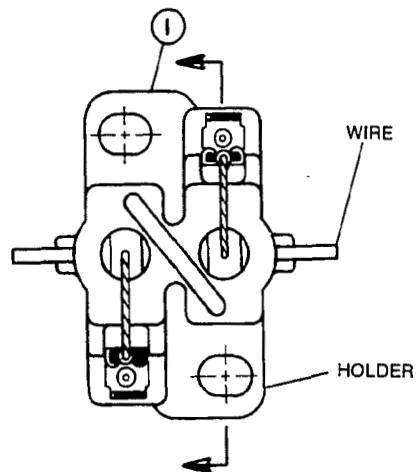
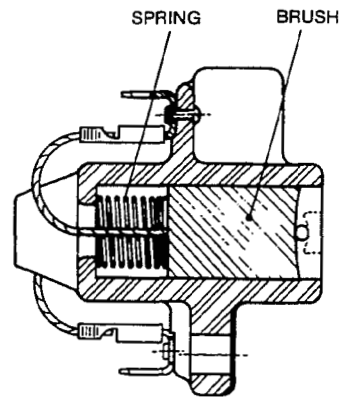

G-1179

FIGURE 8-4. BRUSH REPLACEMENT

6. Install the brush holder. Before tightening the mounting screws, pull out the brush retaining wire and align the holder so that the brushes are centered on the slip rings.
7. Connect the B+ lead to the outer brush terminal and the B-lead to the inner brush terminal.

## Slip Ring Service

1. Examine the slip rings while servicing the brushes.
2. Clean up the slip rings with a commutator dressing stone (available from an Onan dealer) if they are burned, grooved or pitted. The stone should be held against the slip rings while the engine is being cranked. To do this:
  - Remove the brush holder assembly.
  - Disconnect the lead to the positive (+) terminal of the ignition coil so that the engine can be cranked without starting it.
  - Insulate the ends of the two leads that connect to the brush block to keep them from grounding or touching each other.
  - Crank the engine by pressing the start switch while holding the dressing stone against the slip rings. Remove as little material as possible.

**CAUTION** Do not crank the engine for more than 30 seconds at a time, and allow at least 60 seconds between cranks to keep the starter motor from overheating.

## Testing Field Voltage

Field voltage can be tested at the brush holder terminals with a DC voltmeter. Field voltage should fall between 18 and 60 volts. Test at no load and at full load.

## Testing for Open and Grounded Circuits

The generator circuits can be tested without having to disassemble the generator. It is recommended that an ohmmeter be used to check for open circuits and an insulation resistance meter for grounded circuits. An ohmmeter can be used to check for grounded circuits, but it may not be able to detect marginal insulation breakdown.

Replace the component if the insulation resistance is less than 100,000 ohms, or if the circuit is open. Oven dry and retest for insulation resistance before rejecting a part.

**Rotor Tests:** Remove the brush holder access cover and isolate the rotor windings by disconnecting the two leads to the brush holder. Test for an open circuit between the two slip rings (Figure 8-5) and for a grounded circuit between either slip ring and the rotor shaft (Figure 8-6). Rotor resistance should read **10.6 ohms  $\pm$  10 %**.

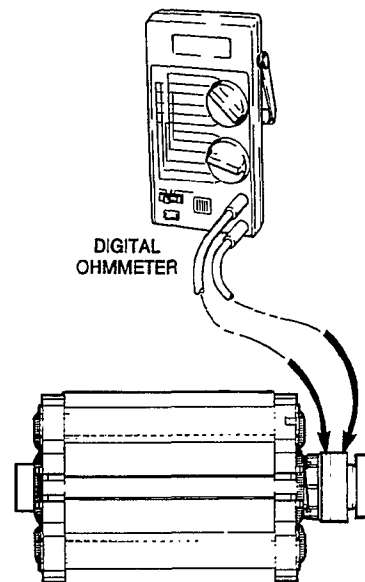

CA-1010-2

FIGURE 8-5. TESTING ROTOR FOR OPEN CIRCUIT

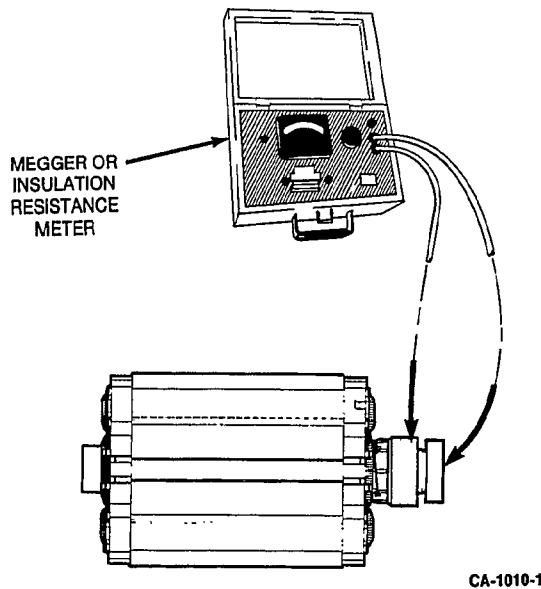

FIGURE 8-6. TESTING ROTOR FOR GROUNDED CIRCUIT

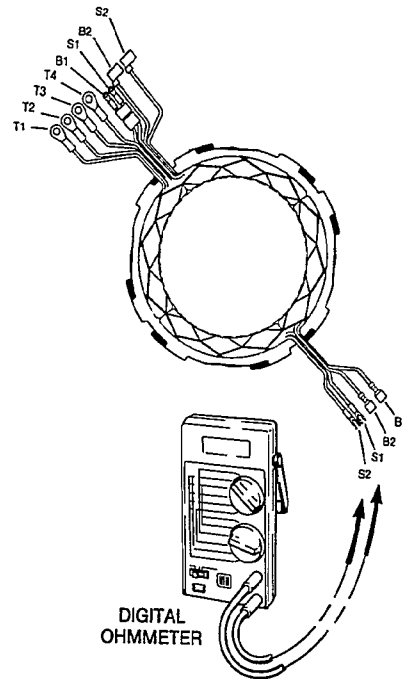

FIGURE 8-7. TESTING STATOR FOR OPEN CIRCUITS

**Stator Tests:** Isolate the stator windings by disconnecting all 12 stator leads (Figures 8-7 and 8-8). It should be noted that leads exit on both sides of the generator. Test for open circuits between T1 - T2, T3 - T4 and B1 - B2, and for grounded circuits between T1, T3 and B1 and the stator laminations or other unpainted grounding point.

See the table on this page for stator resistances.

**STATOR RESISTANCES**

Leads	60 Hz	50 Hz
	Resistance	Resistance
T1-T2	0.259	0.315
T3-T4	0.259	0.315
S1-S2	0.259	0.293
B1-B2	0.069	0.052 (#14 awg)
B1-B2	0.085	0.071 (#18 awg)

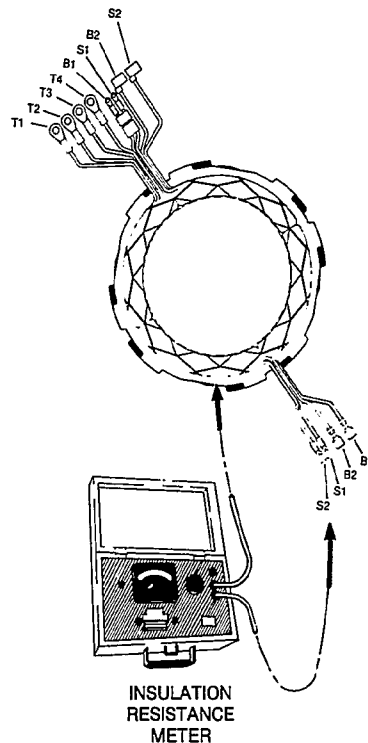
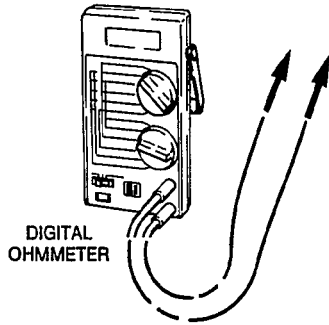
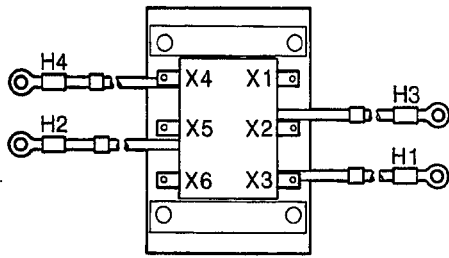

FIGURE 8-8. TESTING STATOR FOR GROUNDED CIRCUITS

**Transformer Tests:** Disconnect all leads from the terminals to isolate the transformer. Test for open circuit between H1 - H2, H3 - H4 and X1 - X6 and for grounded circuits between H1, H3 and X6 and the transformer laminations (Figures 8-9 and 8-10).



DIGITAL OHMMETER

CA-1010-15

FIGURE 8-9. TESTING TRANSFORMER FOR OPEN CIRCUITS

**Bridge Rectifier Tests:** Disconnect the four leads to isolate the bridge rectifier (Figure 8-11). For each AC terminal, the resistance between it and each DC terminal should be low (50 ohms or less) in one direction, and (with the test probes switched) infinite in the opposite direction. Replace the bridge rectifier and voltage suppressor if any diode is faulty.

**Voltage Suppressor Tests:** Disconnect the two leads (Figure 8-11). Replace the suppressor if the resistance is not infinite in both directions.

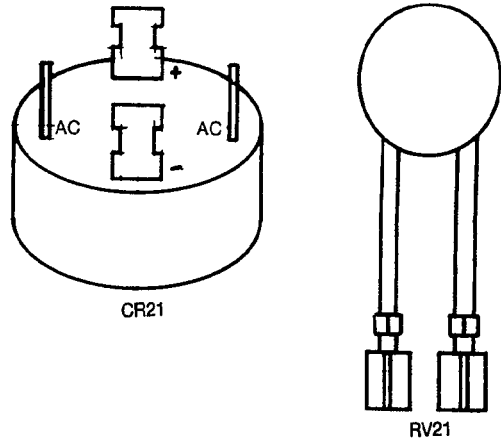

CR21

RV21

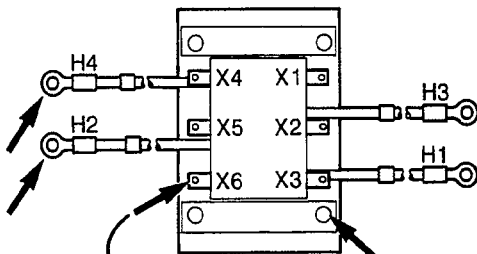

INSULATION RESISTANCE METER

CA-1010-16

FIGURE 8-10. TESTING TRANSFORMER FOR GROUNDED CIRCUITS

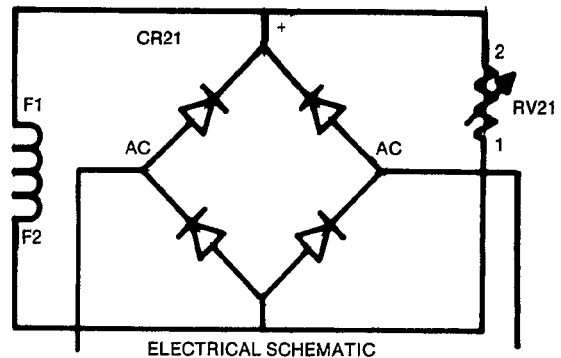

ELECTRICAL SCHEMATIC

ES-1501

FIGURE 8-11. RECTIFIER BRIDGE, VOLTAGE SUPPRESSOR ASSEMBLY

**Voltage Adjustment**

The nominal, no load output voltage is determined by connections at the secondary winding taps of voltage regulating transformer T21. Output voltage at no-load between L1 and L0 or L2 and L0 should be 123- 132 VAC at 63 hertz; and 105 to 115 VAC at 52 hertz. See *Governor/Carburetor Adjustment* under *Engine - Primary Systems*. Reconnect leads TX and T21-X as indicated in Figure 8-2 to adjust the voltage to specification.

## Generator Disassembly

### Removal of the generator from the engine:

1. Remove the set from the boat. See Section 5.
2. Remove the frame for the external panels by removing the four mounting screws.
3. Disconnect the DC wiring harness at the ignition coil, exhaust temperature sensor and coolant temperature sensor.
4. Disconnect the governor rod at the throttle, fuel line at the fuel filter, oil pressure line at the oil pressure sensor, crankcase breather tube at the carburetor adapter, wiring leads at the choke and starter motor grounding straps at the engine adapter and the drip pan.
5. Unbolt the intake manifold/carburetor assembly from the engine.
6. Remove the access cover for the brush holder assembly. Pull the brush pig tails and insert a piece of wire into the small hole in the housing to keep the brushes off the slip rings while assembling and disassembling the generator (Figure 8-12).

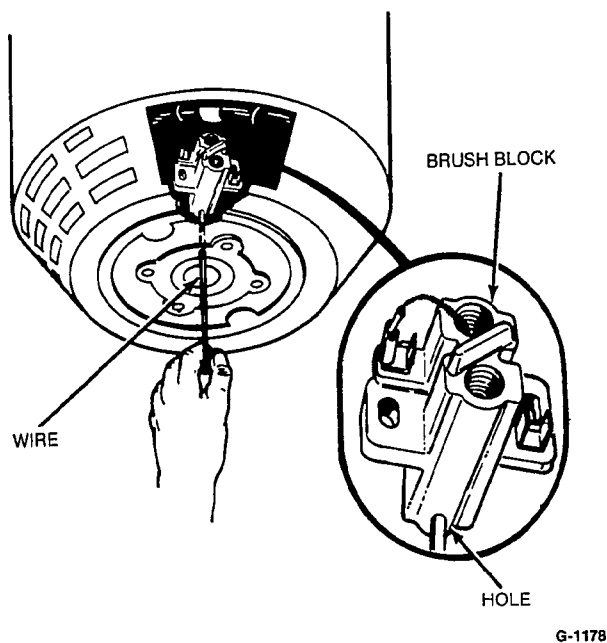

FIGURE 8-12. BRUSH BLOCK ASSEMBLY

7. Secure a lifting eye to the generator housing with four 5/16-18x1 cap screws (Figure 8-13). Raise the generator set with a hoist and then lower it so that the flywheel rests stably on two pieces of lumber.

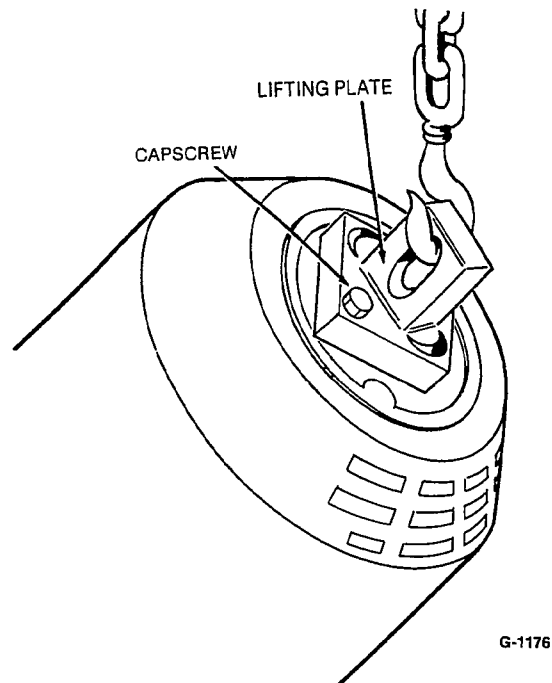

FIGURE 8-13. LIFTING EYE

8. Remove the drip pan by removing the four mounting bolts.
9. Remove the four cap screws that mount the generator to the generator-to-engine adapter.
10. Use a flywheel puller (Figure 8-14) to free the housing from the rotor bearing. When the bearing is clear of the housing bore, lift the housing straight up until it clears the end of the rotor.

**CAUTION** Careless handling can damage the stator windings.

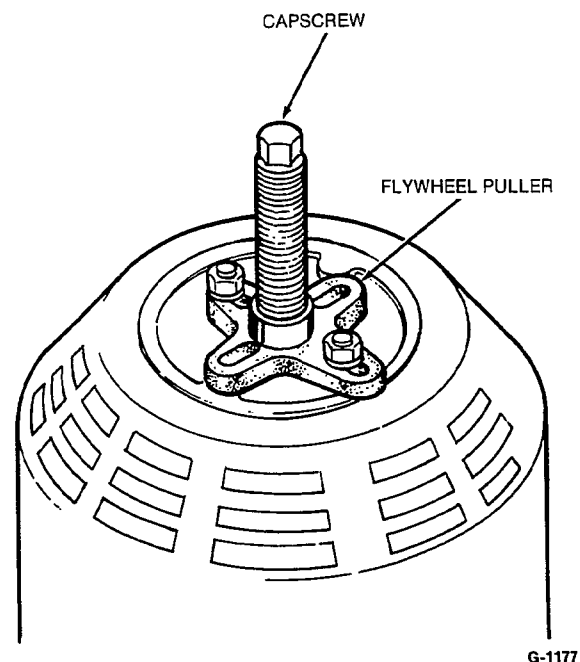
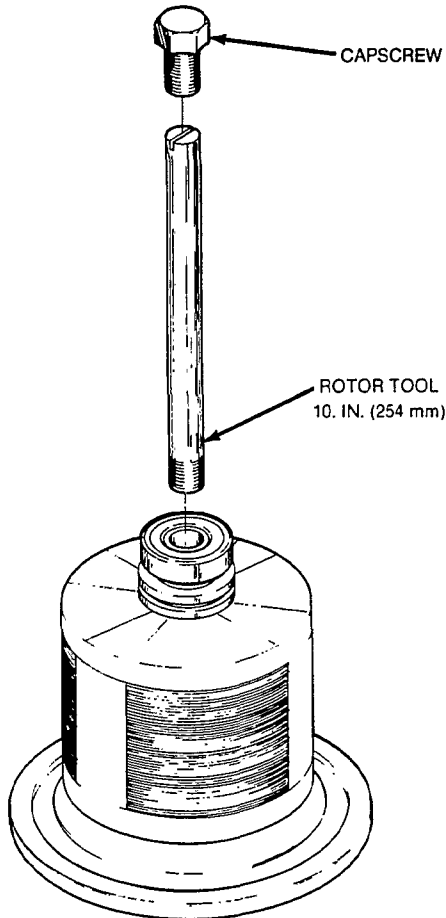

FIGURE 8-14. FREEING HOUSING FROM ROTOR BEARING

- Use a 3/8 inch allen wrench and rubber mallet to loosen the rotor through bolt.
- Remove the rotor through bolt and insert the tool shown in Figure 8-15. Turn the tool with a screwdriver until it bottoms. Thread a 9/16-12x2 inch cap screw into the end of the rotor until it bottoms on the tool and then tighten it until the taper fit between the rotor and crankshaft breaks loose.



G-1175

FIGURE 8-15. ROTOR TOOL

- Remove the rotor bearing with a bearing puller if it is to be replaced. The bearing should be replaced after 5 years, which is the expected life of the bearing grease.

#### **Removal/Replacement of the transformer:**

- Disconnect all wires from their terminals inside the transformer enclosure.
- Remove the four screws on the sides of the enclosure that secure it to the transformer mounting bracket and pull it away from the transformer.

- Remove the four transformer bracket mounting screws.

**CAUTION** *Do not loosen the screws that pass through the transformer laminations, which can alter the transformer air gap.*

- Replacement is the reverse of removal.

#### **Removal/Replacement of the stator:**

- Disconnect the 12 stator leads from their terminals in the AC and DC control boxes.
- Cut the wire ties that secure the leads to the housing. Do not cut the tie supports.
- Remove the four stator clamps and capscrews and carefully lift out the stator.

**CAUTION** *Careless handling can damage the stator windings.*

#### **Generator Assembly**

Assembly is the reverse of disassembly. Pay special attention to the following:

- Use an arbor press to press on the rotor bearing, flush with the end of the shaft. Don't apply pressure to the outer race, or the bearing can be damaged.
- If the stator was removed, align it as shown in Figure 8-1, and insert it carefully. Route the leads through the holes shown and secure with wire ties. Secure the stator with the four clamps and screws.

**CAUTION** *Careless handling can damage the stator windings.*

- Keep the brushes up in the holder with a piece of wire, as described in Item 6 of Disassembly, when mounting the housing.
- The generator housing should be mounted before the rotor through bolt is torqued to specification. Thread the through bolt in just enough to hold the rotor in place while mounting the housing.

**CAUTION** *Tightening the rotor through bolt to full torque before mounting the generator housing can cause rotor misalignment.*

- Secure the ground straps with EIT lockwashers on each side of the eyelets to insure a good bond.



## GENERATOR TROUBLESHOOTING GUIDE



**Many troubleshooting procedures present hazards which can result in personal injury or death. Only qualified service personnel with knowledge of fuels, electricity, and machinery hazards should perform service procedures. Review safety precautions on inside cover page.**

Trouble	Possible Cause	Corrective Action
<p>No AC Output Voltage</p> <p>Note: This condition may cause the generator set to stop when the Start switch is released.</p>	<ol style="list-style-type: none"> <li>1. Open circuit breaker.</li> <li>2. Open circuit between brush block and CR21 rectifier.</li> <li>3. Brushes stuck in holder or not making good contact with slip rings.</li> <li>4. Defective CR21 bridge rectifier</li> <li>5. Open or grounded rotor, stator, or transformer.</li> </ol>	<ol style="list-style-type: none"> <li>1. Locate cause of overload and correct as required. Reset breaker.</li> <li>2. Check for continuity and correct if circuit is open.</li> <li>3. Release brushes if jammed in holder. Clean slip rings if dirty.</li> <li>4. Test rectifier and replace if defective.</li> <li>5. Test each component for open or grounded windings and replace if defective.</li> </ol>
<p>AC Output Voltage Too Low Or Too High</p>	<ol style="list-style-type: none"> <li>1. Engine governor incorrectly adjusted.</li> <li>*2. Open diode in CR21 bridge rectifier.</li> <li>*3. Brushes worn or not making good contact with slip rings.</li> <li>4. If generator frequency is within specified limits but voltage is incorrect transformer is incorrectly connected or defective.</li> <li>*5. Open or grounded circuit in rotor, stator or transformer.</li> </ol>	<ol style="list-style-type: none"> <li>1. Refer to Governor section.</li> <li>2. Test CR21 rectifier and replace if defective.</li> <li>3. Check length of brushes and replace if worn excessively. Clean slip rings.</li> <li>4. Adjust tap connections on transformer secondary windings to obtain correct voltage. Replace transformer if voltage cannot be corrected with adjustments.</li> <li>5. Test each component for open or grounded windings and replace if defective.</li> </ol>
<p>Noisy Generator</p>	<ol style="list-style-type: none"> <li>1. Loose brush holder.</li> <li>2. Worn generator end bearing.</li> <li>3. Rotor and stator rubbing together due to:               <ol style="list-style-type: none"> <li>A. varnish lumps, or</li> <li>B. rotor misaligned with crankshaft.</li> </ol> </li> </ol>	<ol style="list-style-type: none"> <li>1. Tighten brush holder.</li> <li>2. Replace end bearing.</li> <li>3.               <ol style="list-style-type: none"> <li>A. Check for varnish lumps between rotor and stator and remove as required.</li> <li>B. Follow specified assembly procedures to correct rotor to crankshaft alignment.</li> </ol> </li> </ol>

\*Causes low AC output voltage.

## GENERATOR TROUBLESHOOTING GUIDE

**⚠WARNING**

*Many troubleshooting procedures present hazards which can result in personal injury or death. Only qualified service personnel with knowledge of fuels, electricity, and machinery hazards should perform service procedures. Review safety precautions on inside cover page.*

Trouble	Possible Cause	Corrective Action
Generator Overheats	<ol style="list-style-type: none"><li data-bbox="500 472 887 531">1. Generator overloaded due to defective circuit breaker CB22.</li><li data-bbox="500 558 844 646">2. Airflow restricted due to dirt or debris covering vent openings in stator housing.</li><li data-bbox="500 674 865 732">3. Stator windings covered with oil or dirt.</li><li data-bbox="500 760 844 848">4. Open, grounded or shorted circuit in rotor, stator, or transformer.</li><li data-bbox="500 909 778 968">5. Incorrect transformer connection.</li></ol>	<ol style="list-style-type: none"><li data-bbox="1014 472 1318 501">1. Replace circuit breaker.</li><li data-bbox="1014 558 1285 617">2. Clear away all dirt or debris as required.</li><li data-bbox="1014 674 1301 703">3. Clean stator windings.</li><li data-bbox="1014 760 1361 877">4. Test each component for open, grounded, or shorted windings and replace if defective.</li><li data-bbox="1014 909 1377 968">5. Refer to Transformer Voltage Adjustments section.</li></ol>

# Section 9. Engine - Block Assembly

## GENERAL

The engine block assembly includes the engine block, cylinder heads, piston/rod assemblies, crankshaft, camshaft, valve system, lubrication system, timing gears, governor mechanism and bearings.

Most of the procedures in this section require removal of the set from the boat, and the generator and engine primary systems from the block assembly. Refer to the previous sections.

## CYLINDER HEADS

Decarbonize the cylinder heads at the intervals specified in the *Maintenance Schedule* of the Operator's Manual.

1. Drain the engine coolant and disconnect the coolant hoses from the cylinder heads. Refer to *Engine-Primary Systems*.
2. Remove the cylinder head bolts and pull off the cylinder heads.
3. Remove carbon deposits with a wire brush.
4. Install new head gaskets.
5. Reinstall the heads, torquing the bolts in the sequence shown in Figure 9-1, in steps of 5 ft-lbs (7 Nm), until they have been torqued to 29-31 ft-lbs (39 to 42 Nm).
6. Reconnect the coolant hoses and refill the engine with coolant.
7. Retorque the head bolts when the set has run 25 hours.

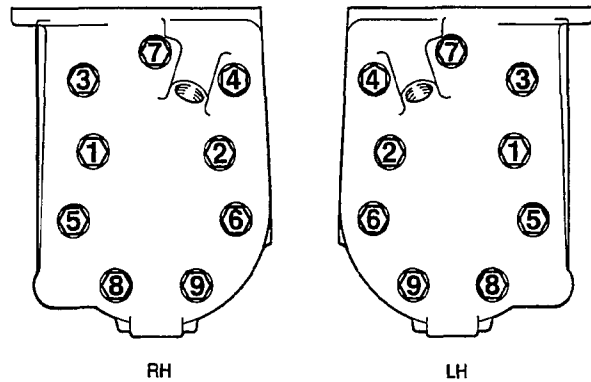

FIGURE 9-1. CYLINDER HEAD TORQUE SEQUENCE

## VALVE SYSTEM

Remove the cylinder heads and valve covers for access to the valves, valve springs, valve guides and tappets (Figure 9-2). A valve spring compressor must be used to remove valves from the cylinder block (Figure 9-3).

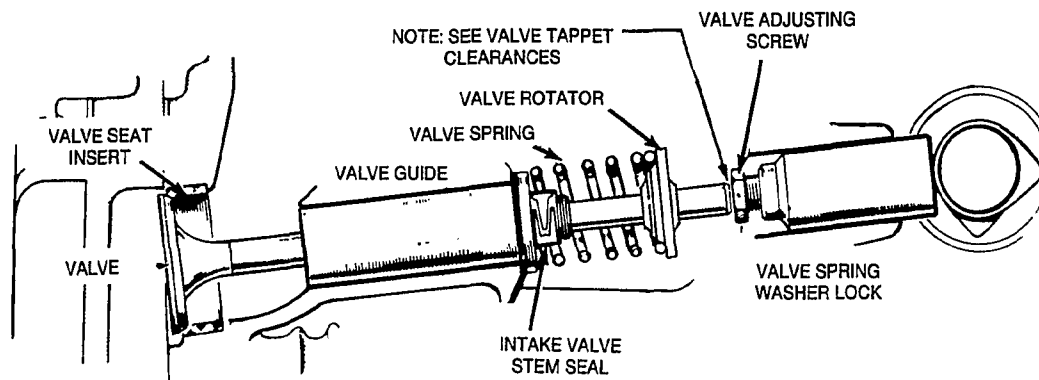

FIGURE 9-2. VALVE SYSTEM

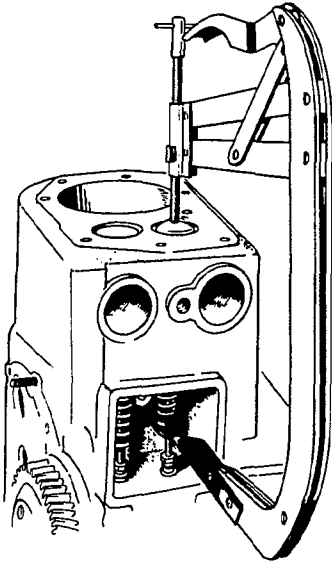

FIGURE 9-3. VALVE SPRING COMPRESSOR

### Inspection

**Valve Face:** Check for burning, pitting, warping, and out-of-roundness (Figure 9-4).

Burning and pitting occur when the valve does not seat tightly. This may be the result of hard carbon deposits on the seat, or of a weak valve spring, insufficient tappet (lifter) clearance, warping, or misalignment of the valve seat and the valve guide. Exhaust valves may warp in the upper stem area because of the exposure to the hot exhaust gas. Out-of-roundness is caused by misalignment of the valve and valve seat because of not having ground the valve seat concentric with the valve guide. Install a new valve and regrind the valve seat if the valve face is burned, pitted, warped or out-of-round.

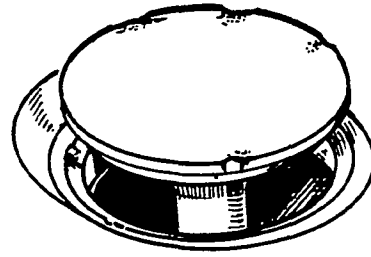

FIGURE 9-4. VALVE FACE

**Stems and Guides:** Check valve stems and guides for wear as shown in Figure 9-5. Use a hole gauge to measure the valve guide bore. When clearance exceeds specifications, replace either the valve, the guide, or both, as necessary. Always regrind the seat to make it concentric with a newly installed guide.

Too much clearance between the intake valve and its guide allows air and oil to be drawn into the cylinder, upsetting carburetion, increasing oil consumption and causing heavy carbon deposits.

**Intake Valve Stem Seals:** Replace the intake valve guide seal with a new one each time the valve and guide are reassembled.

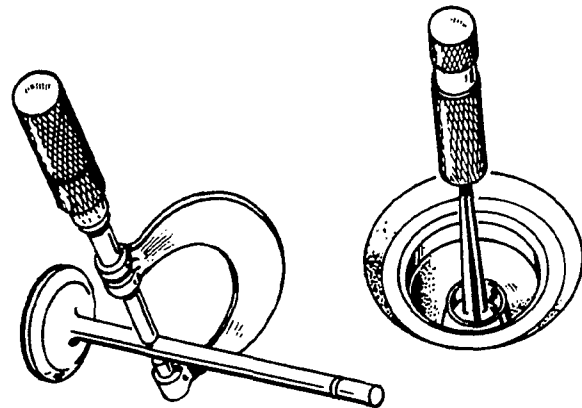

FIGURE 9-5. VALVE STEM & VALVE GUIDE INSPECTION

**Springs:** Check the valve springs for wear on the ends, straightness and strength at valve open and valve closed heights. If spring ends are worn, check the valve rotator for wear also. Check spring free height and straightness by placing the spring on a flat surface next to a square and rotating it against the square. Check spring strength at valve open and valve closed heights using an accurate valve spring tester. Replace any valve spring that is weak, worn or bent.

### Reconditioning Valves and Valve Seats

The specified valve face and valve seat angles are 44 degrees and 45 degrees, respectively. The one degree difference in angle results in a sharp line of contact between the valve and valve seat (Figure 9-6).

Hand lapping is not recommended since it breaks down the sharp line of contact.

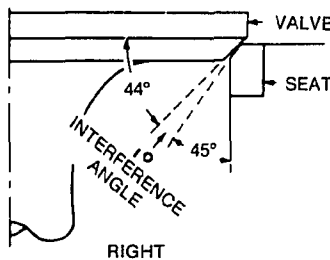

VT-1021

FIGURE 9-6. VALVE INTERFERENCE ANGLE

A valve must have a minimum of 1/16-inch (1.6 mm) margin (Figure 9-7). Replace a valve with less margin since it will heat up excessively and burn.

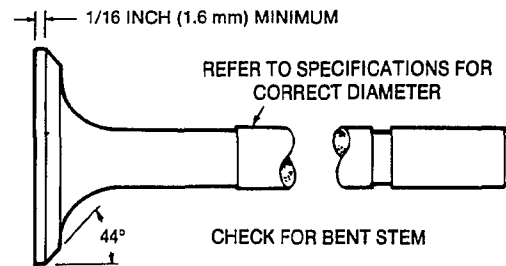

VT-1022

FIGURE 9-7. VALVE MARGIN

Replace a warped or pitted valve that cannot be cleaned up without removing too much margin. To make a valve gas-tight, every trace of pitting must be removed from the valve face and seat.

Grind valve seats with a 45-degree stone. The seat band should be 1/32 to 3/64 inch (0.79 to 1.2 mm) wide. Grind only enough to ensure proper seating. Narrow the seat width if necessary with a 30 or 60-degree stone.

Check the tightness of valve seating with machinist's blueing. Make several marks at regular intervals around the valve face and then insert the valve and rotate it one quarter turn against the seat. The blueing should rub off evenly at all points around the valve seat. The line of contact should be at the center of the valve face.

### Valve Guide Replacement

**Removal:** To prevent damage to the valve guide bores, use an electric drill with a wire brush to remove deposits from the valve head end of the guides before removing them. Drive the guides out with a hammer and valve guide driver.

**CAUTION** Be careful not to damage the tappet bores when driving out the valve guides.

**Installation:** Clean up the guide bores with crocus cloth and lubricate them with oil. Figure 9-8 illustrates the recommended way to pull up the guides into the bores. Make sure the shoulders bottom. Install the intake valve stem seals on the intake valve guides.

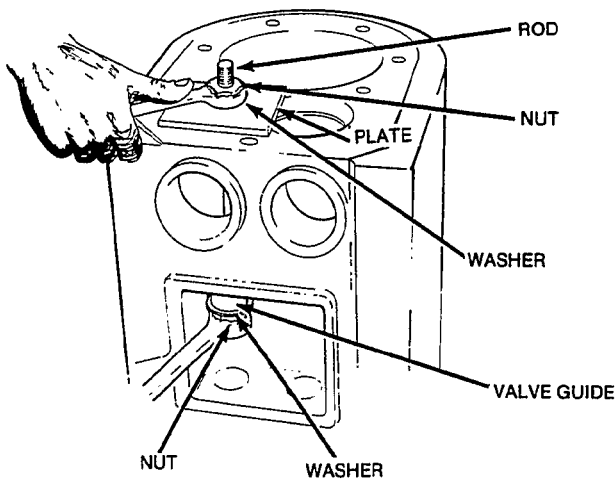

VT-1023-2

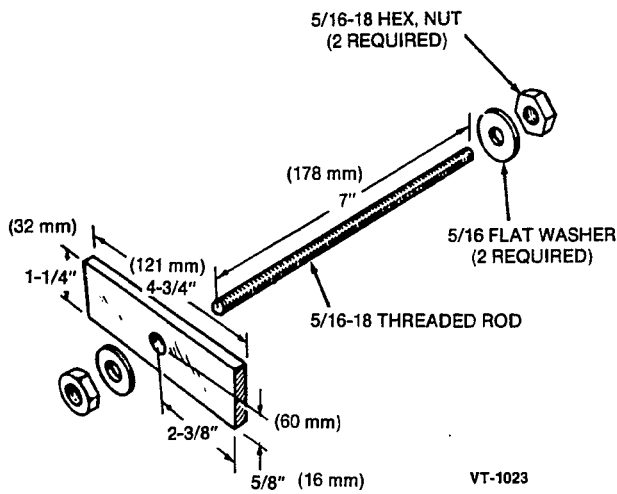

VT-1023

FIGURE 9-8. VALVE GUIDE INSTALLATION

### Valve Seat Inserts

Remove a valve seat insert that is loose, cracked or pitted beyond repair. Use the appropriate extraction tool as shown in Figure 9-9.

1. Clean out any carbon deposits from the inside of the valve seat insert.
2. Adjust the puller depth using a new valve seat insert as a guide.
3. Position the puller on the valve seat and tighten the hex nut.
4. Attach a slide hammer or puller.

5. Tighten the hex nut between blows or each turn of the puller screw.
6. If the insert bore is damaged by extracting the old insert, use a valve seat cutting tool to bore to the next oversize.

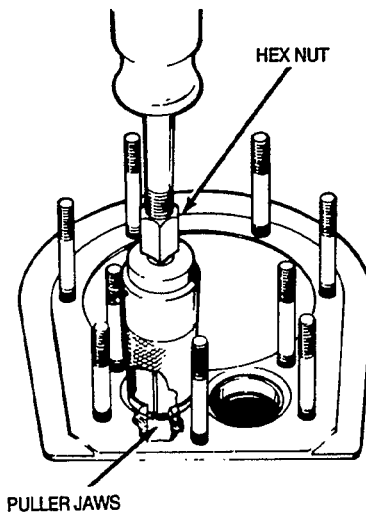
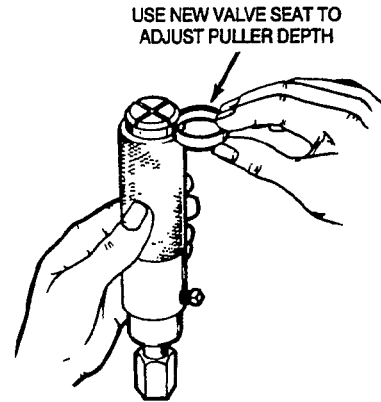
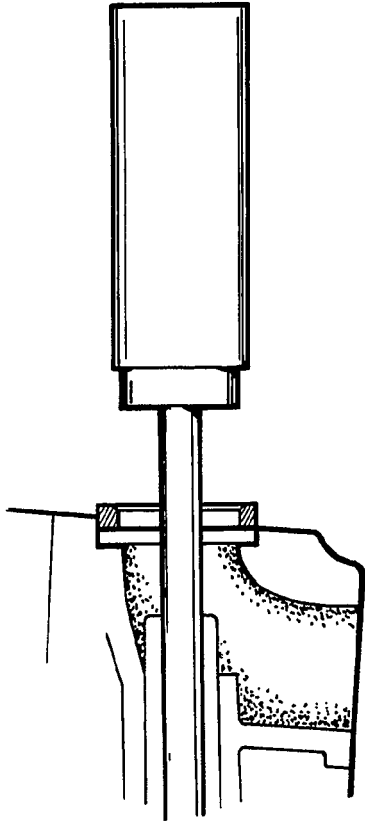

FIGURE 9-9. REMOVAL OF VALVE SEAT INSERT

7. Use a valve seat insert driver and a hammer to install a new insert. Insert the pilot of the tool into the valve guide and drive the valve seat insert evenly to the bottom of the bore (Figure 9-10). Installation will be easier if the insert is first cooled in dry ice for one-half hour.

**▲WARNING**

*Dry ice can injure the skin. Handle with dry gloves.*



VT-1025-1

FIGURE 9-10. INSERTING NEW VALVE SEAT

5. Adjust left side tappets: Rotate the crankshaft one full turn clockwise until the timing marks line up again and the pistons are flush with the cylinder head surfaces. You are now at top dead center. Repeat same procedure used in Step 4.
6. Rotate the crankshaft one full turn clockwise and check/reset right side tappet clearances.

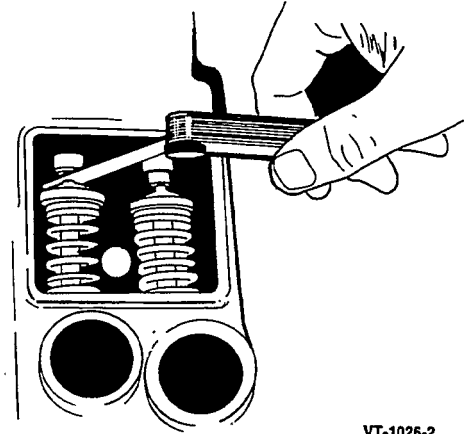

VT-1026-2

FIGURE 9-11. MEASURING VALVE CLEARANCE

8. Grind the valve seat. See *Reconditioning Valves and Valve Seats* above.

### Tappet Adjustment

1. Rotate the crankshaft in a clockwise direction, as viewed from the flywheel end, and watch for the intake valve (larger of 2 valves) on the left side to open and close.
2. Continue to rotate until the TC mark on the flywheel lines up with the TC mark on the gear cover. The top of the pistons should be flush with the cylinder head surfaces; you are now at top dead center.
3. Check to see that intake and exhaust valves on the right side are both closed.
4. Adjust right side tappets: adjust valve to tappet clearances by holding the tappet with 9/16 tappet wrench, and using a 7/16 tappet wrench, turn the self-locking tappet adjustment screw to obtain .010 inch clearance. Use the feeler gauge as shown in Figure 9-11.

## PISTON/ROD ASSEMBLIES

### Removal and Disassembly

Remove carbon from the top of each cylinder bore and check for a ridge. Remove ridges (Figure 9-12) with a ridge reamer before removing the pistons.

**CAUTION** Forcing the piston from the cylinder before removing the ridge can damage the piston ring lands and break the rings. Be careful not to gouge the cylinder wall with the ridge reamer.

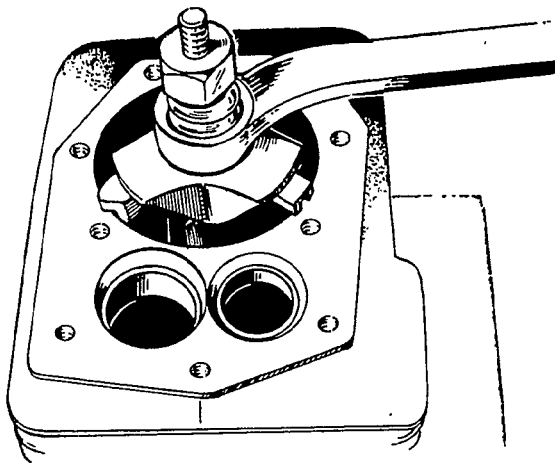

CT-1058

FIGURE 9-12. REMOVING THE WEAR RIDGE

To remove the piston/rod assemblies, turn the crankshaft until the pistons are at the bottom of their stroke. Remove the connecting rod caps and push the rods and pistons out the top of the cylinder with the wood handle of a hammer. Mark the pistons, rods and rod caps for reassembly to the same parts in the same cylinder.

Remove the piston pin retainer from each side of the piston and push the pin out.

The piston is fitted with two compression rings and one oil control ring. Remove these rings from the piston using a piston ring spreader (Figure 9-13).

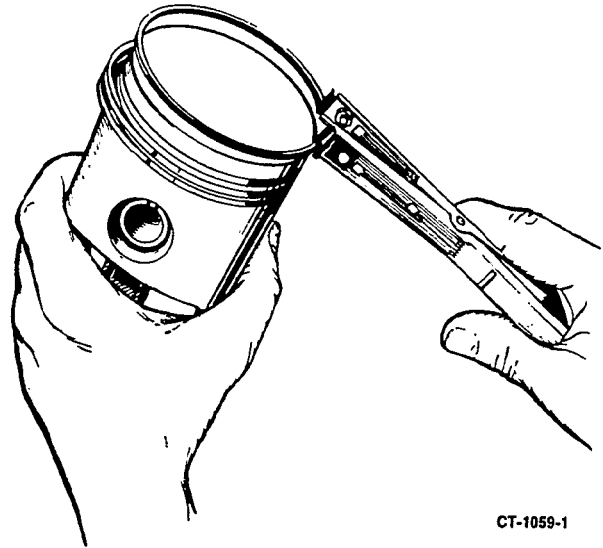

CT-1059-1

FIGURE 9-13. REMOVING PISTON RINGS

Clean the piston ring grooves with a groove cleaner or the end of a broken ring filed to a sharp point (Figure 9-14). Take care not to scrape metal from the sides of the grooves. Thoroughly clean the piston and rod with hot soapy water or other non-corrosive solvent.

**CAUTION** Most commercial engine cleaning solvents are corrosive to aluminum. Check compatibility before using to clean pistons and connecting rods.

Wire brushing removes metal from aluminum pistons and rods. Use natural or plastic fiber brushes for cleaning.



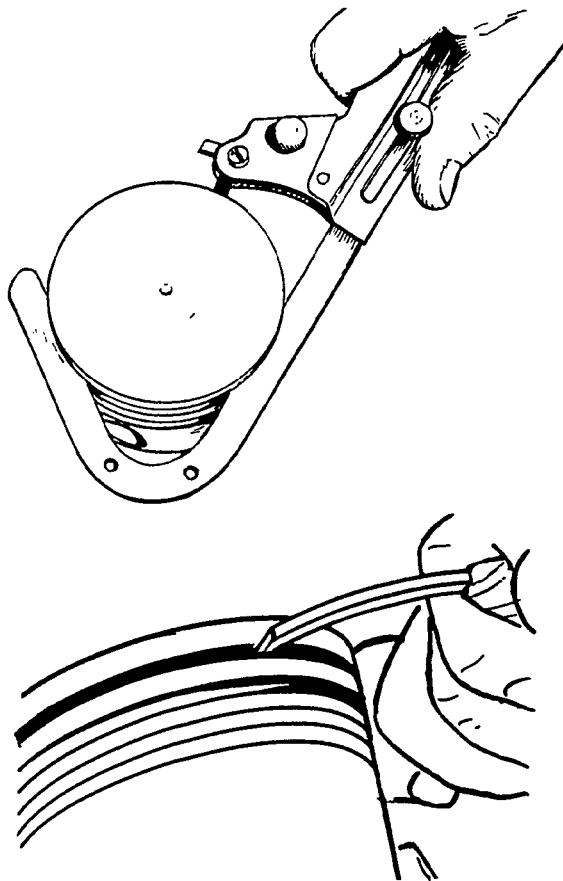

CT-1060

FIGURE 9-14. CLEANING RING GROOVES

### Piston Inspection

Inspect the piston for fractures at the ring lands, skirts and pin bosses. Check for wear at the ring lands using a new ring and feeler gauge as shown in Figure 9-15. Replace the piston if the side clearance of the top compression ring exceeds 0.008 inch (0.20 mm).

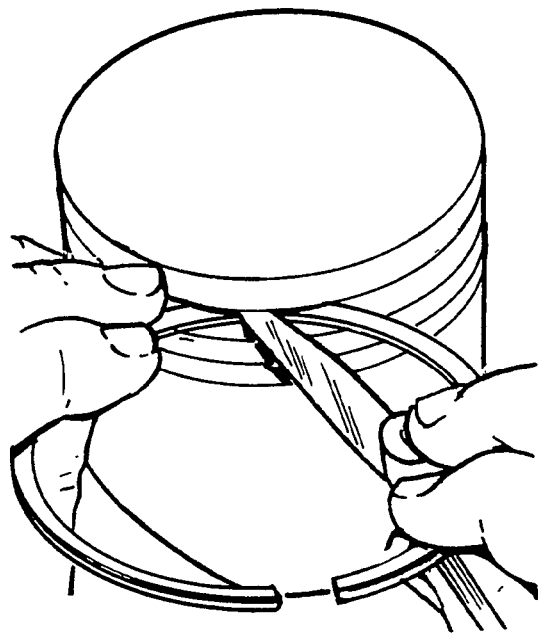

CT-1061

FIGURE 9-15. CHECKING RING LAND CLEARANCE

Excessive ring side clearance can result in broken rings, and new rings in worn grooves have poor cylinder wall contact (Figure 9-16).

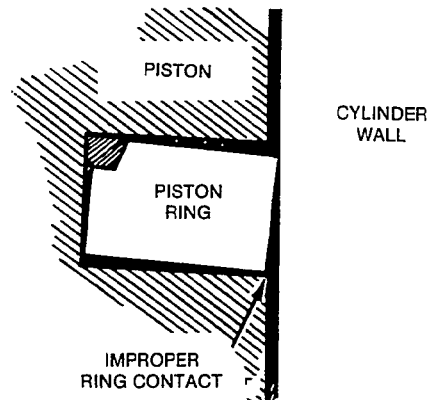

CT-1062

FIGURE 9-16. NEW RING IN WORN RING GROOVE

Replace the piston if it shows signs of scuffing, scoring, worn ring lands, fractures or other damage. Pistons and piston rings are available in standard size and in 0.005, 0.010, 0.020, 0.030 and 0.040 inch oversizes. See *Dimensions and Clearances*.

### Connecting Rod Inspection

Replace the connecting rods if they have deep nicks, stripped threads, fractures, scored bores, or bores out-of-round more than 0.002 inch (0.05 mm).

Use a new piston pin to check the piston pin bore for wear. A push-fit clearance is required. If a new piston pin falls through a dry bore as a result of its own weight, replace the connecting rod.

Steel connecting rods have insert bearings. The crank-pin insert bearings for steel connecting rods and aluminum rods are available in standard size and in 0.002, 0.010, 0.020 and 0.030 inch undersizes. Replace a steel connecting rod with a steel connecting rod and an aluminum rod with an aluminum rod. See *Dimensions and Clearances*.

### Piston Pin Inspection

Replace the piston pin if it is scored or out-of-round more than 0.002 inch (0.05 mm).

### Piston Clearance

The proper piston clearance is obtained when the piston and cylinder oversizes match. Measure the piston diameter at the location shown in Figure 9-17 and compare with the bore diameter of the cylinder to confirm that the oversizes match.

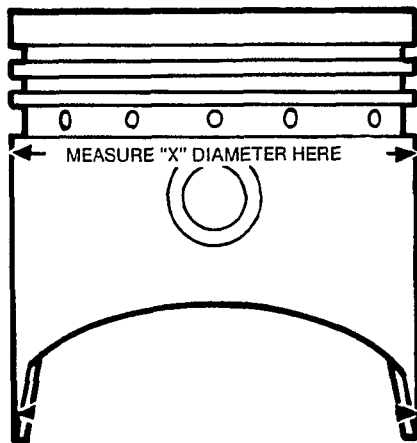

CT-1063

FIGURE 9-17. PISTON CLEARANCE MEASUREMENT

### Piston Ring Gap

Before installing new rings on the piston, check the ring gap by placing each ring squarely in the cylinder (push it in with the piston) at a position corresponding to the bottom of its travel (Figure 9-18). Do not file the ends to make them fit. Obtain the right rings, or check again to make sure that the bore is within specifications.

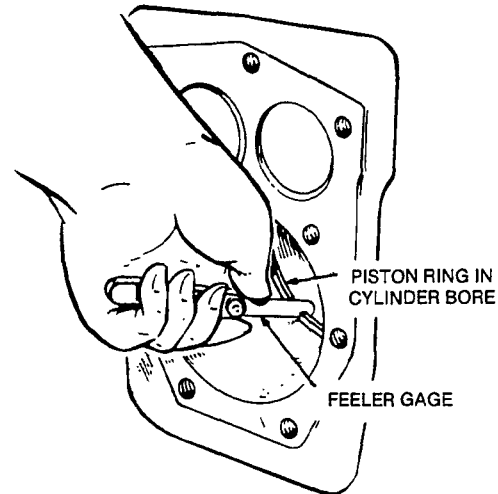

CT-1064

FIGURE 9-18. CHECKING RING GAP

### Piston/Rod Assembly Installation

Lubricate all parts with clean oil. Line up the rod and piston pin bores and push in the piston pin. Snap in the lock ring at each end to retain the piston pin in the piston.

Install the piston rings. Start with the oil control ring and work up. Use a piston ring spreader to prevent twisting and over expansion. Compression rings are marked with a dot or the word "top" on the side that must face up. The oil control ring has an expander. Install the expander first. Locate the expander gap 180 degrees from the ring gap. Space the ring gaps one third of the way around from each other.

**Install the piston assemblies as follows:**

1. Turn the crankshaft until the crankpins are at the bottom of their stroke.
2. Lubricate the pistons and cylinders and compress the rings with a ring compressor (Figure 9-19)

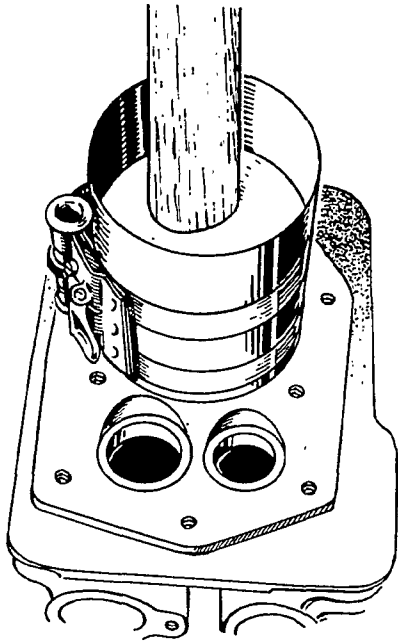

CT-1066

**FIGURE 9-19. INSTALLING PISTON**

3. Note that the connecting rod cap bolts are offset slightly to one side of the cap. Position the piston/rod assemblies in the cylinder block as shown in Figure 9-20 such that the connecting rod cap bolt offsets are outward.

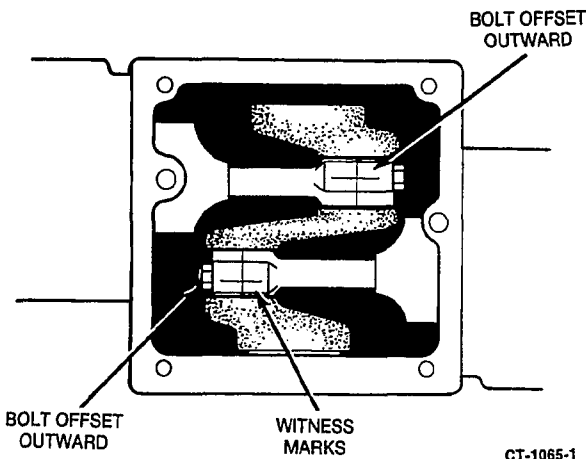

CT-1065-1

**FIGURE 9-20. ROD CAP ALIGNMENT**

4. Tap the pistons down into the cylinder with the wood handle of a hammer until the connecting rods seat on the crank pins.
5. Use Plasti-gage (green code) as shown in Figure 9-21 to check the crankpin bearing clearance:
  - A. Wipe oil off the connecting rod bearing and crankpin.
  - B. Place a piece of Plasti-gage across the full width of the cap where it will be in line with the connecting rod.
  - C. Attach the connecting rod cap and bearing and torque the bolts as specified under Torque Specifications. Note the witness marks on the rod and cap (Figure 9-20). These must line up. Make sure the crankshaft does not turn, or the Plasti-gage will smear.
  - D. Remove the connecting rod cap and check the width of the flattened plasti-gage against the scale on the envelope.

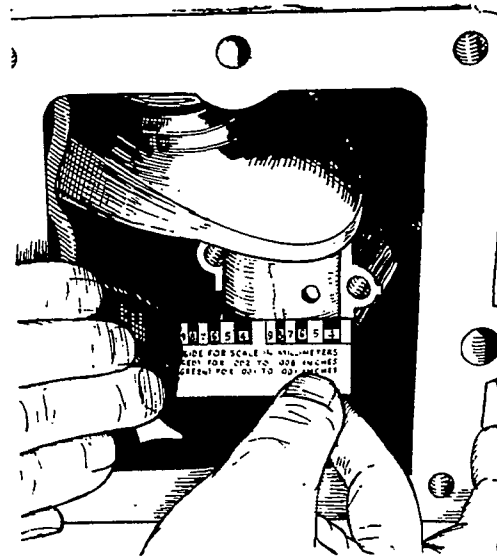

CT-1067

**FIGURE 9-21. MEASURING BEARING CLEARANCE WITH PLASTI-GAGE.**

6. Lubricate the crankpin, attach the cap again and torque the cap bolts to specifications.
7. The rod should move freely from side-to-side between the shoulders of the crankpin. If it doesn't, loosen the cap bolts and tap the cap, and try again. Repeat the procedure until there is free side-to-side movement.
8. Crank the engine by hand to check that all bearings are free.

## FLYWHEEL

A flywheel puller is required to break the taper fit between the flywheel and crankshaft.

1. Turn the flywheel cap screw out two turns.
2. The flywheel has tapped holes for attaching the puller (Figure 9-22). The center screw of the puller should bear on the head of the flywheel cap screw.
3. Alternately tighten the puller bolts until the flywheel breaks loose.
4. Remove the capscrew, flywheel and flywheel key.

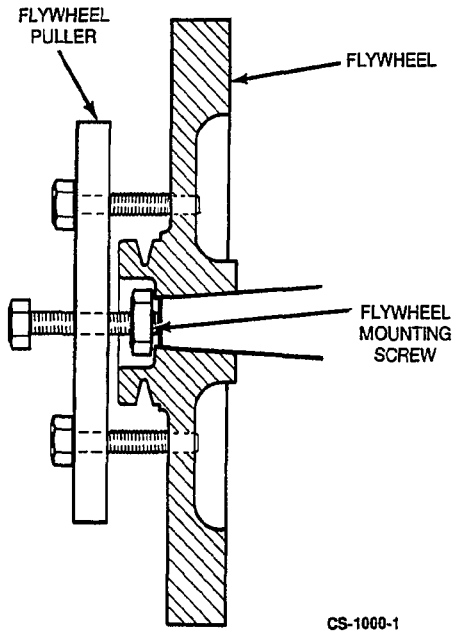

FIGURE 9-22. REMOVING THE FLYWHEEL

## GEAR COVER

Remove the flywheel, flywheel key and gear cover mounting screws. Tap the gear cover gently, using a soft-faced hammer to loosen it.

When installing the gear cover, make sure the pin in the gear cover engages the hole in the governor cup that has the nylon bushing in it (Figure 9-23). Turn the governor cup so that the hole is at the three o'clock position.

Be careful not to damage the gear cover oil seal. Keep the oil seal driver on to keep the seal expanded while the crankshaft slips through. Refer to *Oil Seals*, below, for details about oil seal installation.

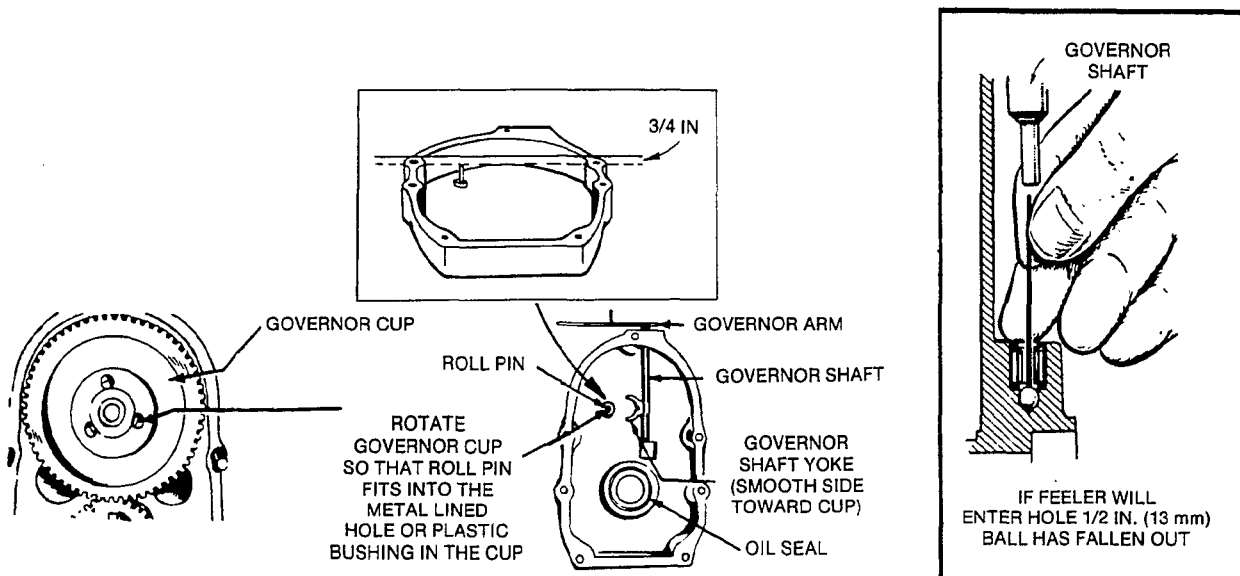

FIGURE 9-23. GEAR COVER ASSEMBLY

## GOVERNOR CUP

With the gear cover removed, the governor cup can be taken off after removing the snap ring from the camshaft center pin (Figure 9-24). Catch the flyballs while sliding the cup off.

Replace any flyball that is grooved or has a flat spot. If the arms of the ball spacer are worn or otherwise damaged, replace the whole gear/spacer assembly. The governor cup must spin freely on the camshaft center pin without excessive looseness or wobble. If the race surface of the cup is grooved or rough, replace it with a new one.

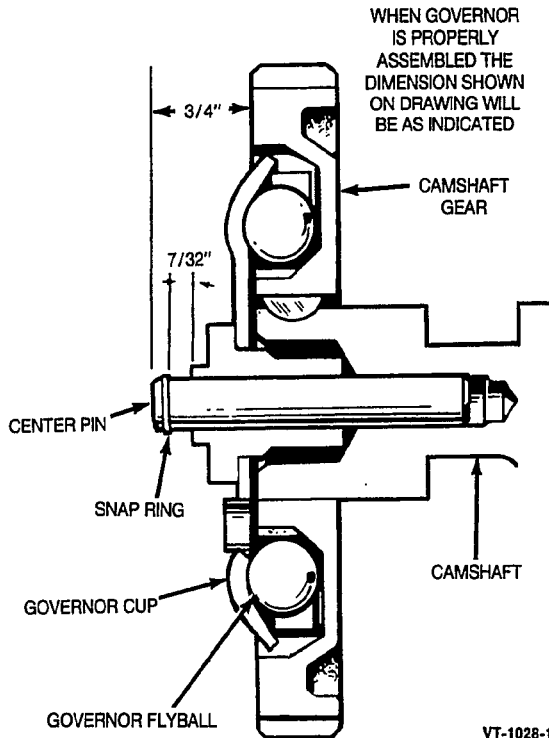

FIGURE 9-24. GOVERNOR CUP

If a new governor cup is being installed, the distance from the snap ring on the center pin to the face of the governor cup must be exactly 7/32 inch (5.5 mm) when the cup is pressed back against the flyballs as far as possible. If the distance is too small, carefully dress the face of the cup as required, being sure to remove any burr from the inside of the cup bore. If the distance is more than 7/32 inch (5.5 mm), carefully press the pin in the required amount. Do not go too far since the pin cannot be pulled back out without damage to it. Replace the flyballs, spacing them evenly, and secure the governor cup with the snap ring.

## TIMING GEARS AND CAMSHAFT

If replacement of either of the crankshaft or camshaft gears becomes necessary, both gears should be replaced, since they are a matched set.

To remove the crankshaft gear, remove the snap ring and retainer washer and bolt on a gear pulling ring (Figure 9-25). Attach a gear puller to the pulling ring and remove the gear.

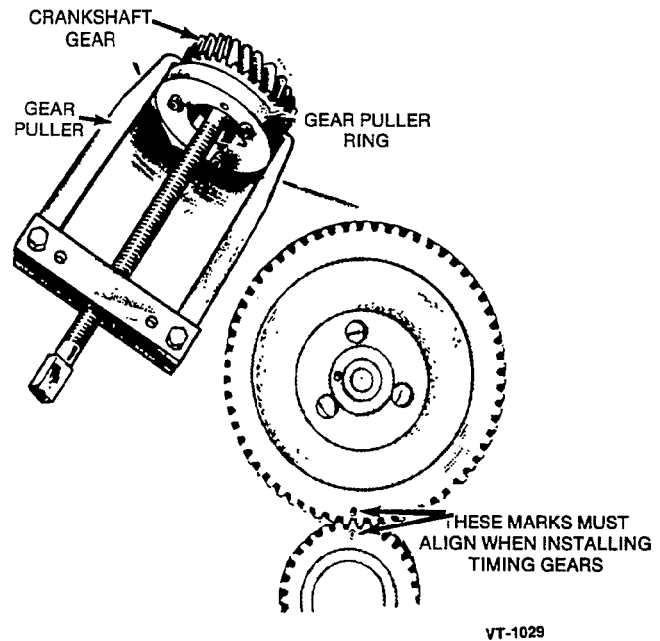

FIGURE 9-25. TIMING GEAR REMOVAL AND INSTALLATION

The camshaft and gear are removed as an assembly. Remove the valve tappets before removing the camshaft/gear assembly.

To reinstall the crankshaft gear, heat it in an oven to 325°F (168°C). Make sure the key is in place, and tap the gear down to the shoulder on the crankshaft. Attach the retaining washer and snap ring after the camshaft gear has been engaged.

Each timing gear is stamped with "O" near the edge. The gear teeth must mesh so that these marks line up. When installing the camshaft gear/shaft assembly, be sure that the thrust washer is properly in place behind the camshaft gear. Then install the crankshaft gear retaining washer and lock ring.

## LUBRICATION SYSTEM

Drain the oil before removing the oil base. Always use a new gasket when replacing the oil base.

An oil pump provides a constant flow of oil to the engine parts and a full flow spin-on filter keeps the oil clean. The oil supply collects in the oil base where it is picked up by the oil pump pick-up cup. A by-pass valve is used to control oil pressure.

The oil pump is mounted on the front of the crankcase behind the gear cover and is driven by the crankshaft gear. The inlet pipe and screen assembly is attached directly to the pump body. A discharge passage in the cover of the pump registers with a drilled passage in the crankcase that leads to the front main bearing via the oil filter. A circumferential groove in the front main bearing allows oil to cross over to a drilled passage that leads to the front camshaft bearing. A copper crossover tube carries oil to the rear main bearing. The connecting rod journals are lubricated through drilled passages from the main journals. The oil overflow from the bypass valve lubricates the camshaft drive gears.

Normal oil pressure is 30 psi (207 kPa) or higher when the engine is at normal operating temperature. Inspect the oil system for faulty components if oil pressure is low.

### Oil Pump

Check the oil pump thoroughly for worn parts (Figure 9-26). Oil the pump to prime it before reinstalling. Except for the gaskets and pick-up cup, individual components of the pump are not available. Install a new pump assembly if any parts are worn.

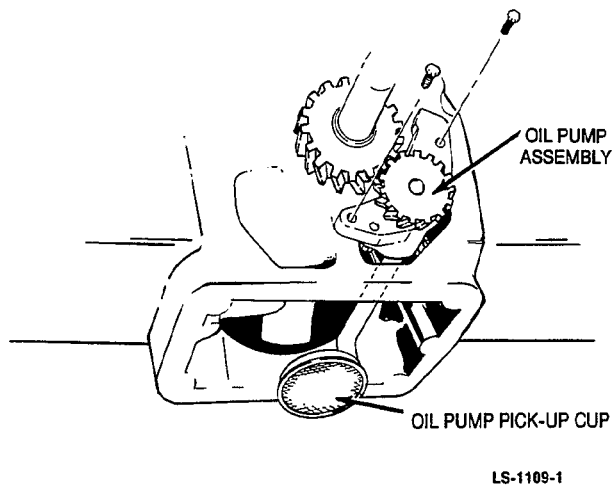

FIGURE 9-26. OIL PUMP ASSEMBLY

### Oil By-pass Valve

The oil by-pass valve controls oil pressure by allowing excess oil to drain back to the crankcase. The valve (Figure 9-27) is non-adjustable and normally needs no maintenance. If oil pressure is abnormally low or high inspect the valve as follows:

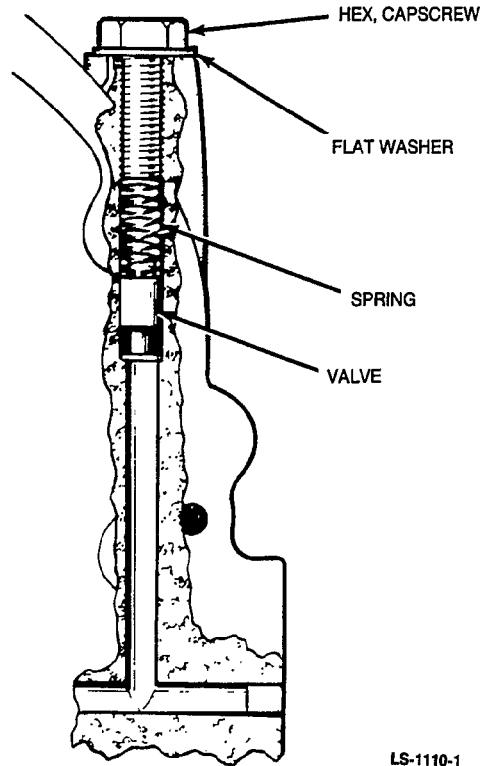

FIGURE 9-27. OIL BYPASS VALVE

1. Remove the cap screw and copper washer located at the top of the block next to the gear cover.
2. Remove the spring and plunger with a magnetic tool.
3. Check the valve bore and clean away any accumulation of metal particles that could cause erratic valve action.
4. Clean the plunger and spring.
5. Replace the plunger if its diameter is not 0.3105-0.3125 inches (7.89-7.94 mm).
6. Replace the spring if its free length is not approximately 1 inch (25.4 mm) or the load required to compress it to .5 inches (12.7 mm) is not within 2.4-2.8 lbs. (10.7-12.5 N).

### Valve Compartment Oil Drain

A drain hole from the valve compartment allows oil to enter the crankcase. This hole must be unobstructed to provide for proper drainage of oil from the valve compartment.

### Oil Filter Adapter

An oil filter adapter is provided for mounting the oil filter to the engine block (Figure 9-28).

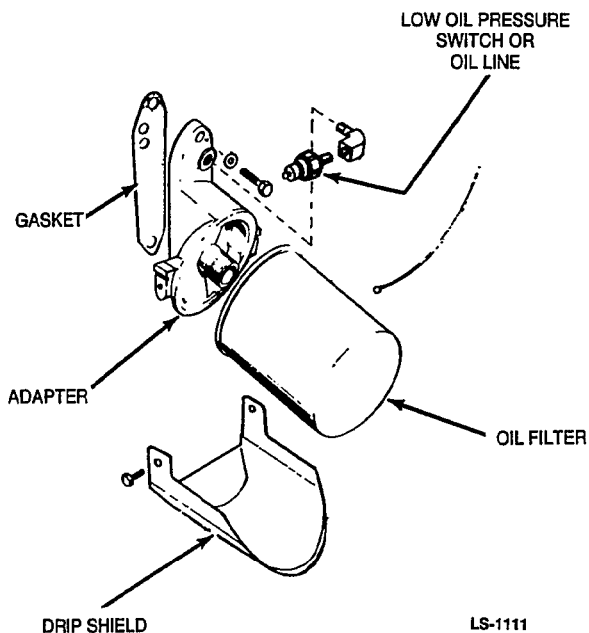

FIGURE 9-28. OIL FILTER AND ADAPTER

The adapter is secured by two screws. Install the adapter with a new gasket. Make sure the two small oil holes in the block, gasket and adapter line up. The gasket should be installed dry. Use a non-hardening sealer on the screw threads and torque to specifications.

## CYLINDER BLOCK

The cylinder block is the main support for all other basic engine parts. Remove the piston/rod assemblies, crankshaft, camshaft, oil pump, oil by-pass valve and oil filter adapter. Clean the block and look for cracks and wear.

### Cleaning

1. Scrape all old gasket material from the block.
2. Remove grease and scale from the engine block with commercial cleaning solution or hot soapy water and rinse thoroughly with hot water.

### General Inspection

After thorough cleaning and drying inspect the block for any condition that would make it unfit for further use.

1. Check for cracks. Minute cracks can be detected with commercially available spray-on systems for detecting cracks. Always replace a cracked engine block.
2. Inspect all machined surfaces and threaded holes. Carefully remove any nicks or burrs from machined surfaces. Clean out tapped holes and clean up any damaged threads.
3. Check the cylinder head matching surfaces for flatness with a straight edge and a 0.003 inch (0.08 mm) feeler gauge.

### Cylinder Bore Inspection

Inspect the cylinder bores for scuffing, scoring and wear. If a cylinder bore is scuffed, scored or worn, it must be machined for the next oversize piston.

If the cylinder bore looks good, check it for wear, taper and out-of-roundness as follows:

1. Use a cylinder bore gauge, telescope gauge, or inside micrometer to measure the bore diameter. Take four measurements: two at the top of ring travel, parallel and perpendicular to the crank, and two at the bottom of ring travel, parallel and perpendicular to the crank.
2. Record measurements taken at the top and bottom of piston travel as follows (Figure 9-29).
  - A. Measure and record as "A" the cylinder bore diameter parallel to the crankshaft near the top of the cylinder bore where the greatest amount of wear occurs.
  - B. Measure and record as "B" the cylinder bore diameter parallel to the crankshaft at the bottom of piston travel.
  - C. Measure and record as "C" the cylinder bore diameter perpendicular to the crankshaft near the top of the cylinder bore where the greatest amount of wear occurs.
  - D. Measure and record as "D" the cylinder bore diameter perpendicular to the crankshaft at the bottom of piston travel.

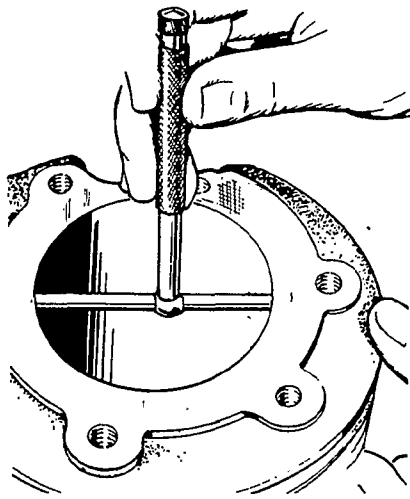

TOP END OF CYLINDER

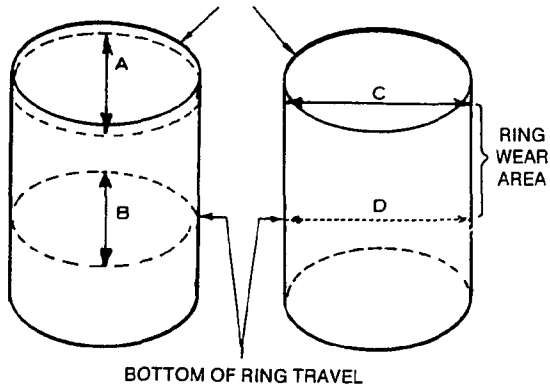

C-1090

FIGURE 9-29. METHODS OF MEASURING THE DIAMETER OF A CYLINDER BORE

- E. Reading "A" subtracted from reading "B" and reading "C" subtracted from reading "D" indicate cylinder taper. If taper exceeds 0.005 inch (0.13 mm), machine the cylinder to accommodate the next oversize piston.
- F. Reading "A" compared to reading "C" and reading "B" compared to reading "D" indicate whether or not the cylinder is out-of-round. If out-of-roundness exceeds 0.003 inch (0.08 mm), the cylinders must be machined to the next oversize.

## Machining the Cylinder Bore

Oversize pistons and rings will fit with the required clearance in cylinders machined to the matching oversize (standard bore plus 0.005, 0.010, 0.020, 0.030 or 0.040 inches). There is no need to adjust or "fit" pistons and rings. Pistons and rings should be measured as described below to confirm the correct sizes. Boring or honing must be accurate and remove just enough metal for the smallest oversize possible. The finish hone should leave a 20 to 40 microinch crosshatch finish angled at 20 to 25 degrees in both directions (Figure 9-30). The crosshatch finish is necessary for quick break-in of the piston rings.

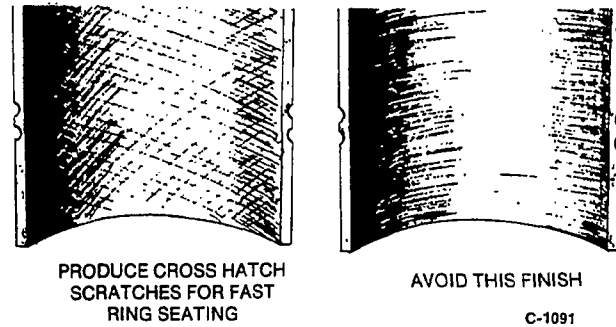

FIGURE 9-30. CROSSHATCHING

Clean the cylinders after machining with hot, soapy water and a brush. A clean white rag will not soil when the cylinder walls are clean. Dry the cylinders and coat them with oil.

**CAUTION** *Never use gasoline or commercial cleaners to clean a cylinder bore after deglazing or honing. These solvents will not remove abrasives. Abrasives not removed from the cylinders will rapidly wear rings, cylinder walls, and bearings.*

## Deglazing the Cylinder Bore

Deglaze the cylinder bores before installing new rings if the bores look good and there is not enough wear, taper or out-of-roundness to warrant machining. Deglazing is necessary for quick break-in of the piston rings, and does not increase the bore diameter. The original pistons with new rings can then be used. Proceed as follows:

1. Wipe the cylinder bores with a clean cloth that has been dipped in light engine oil.
2. Use a brush type deglazing tool with coated bristle tips.



3. Drive the tool with a slow-speed drill. Move the deglazing tool up and down in the cylinders rapidly enough to obtain a crosshatch finish as shown in Figure 9-30. Ten to twelve complete strokes should be sufficient.
4. Clean the cylinders after deglazing with hot, soapy water and a brush. A clean white rag will not soil when the cylinder walls are clean. Dry the cylinders and coat them with oil.

## BEARINGS

Press out the crankshaft and camshaft bearings with the appropriate drivers. Support the block to prevent damage to the casting or the bore. Remove the expansion plug for access to the rear camshaft bearing.

### Camshaft Bearings

Lubricate the bearings with light oil. Using the appropriate driver, start the bearing straight from outside the block. The oil holes must line up so that they are at least half open (Figure 9-31). Press the bearings in until the flange on the driver bottoms. Pound a new expansion plug into the counterbore around the rear bearing. Use Permatex around the edge of the plug.

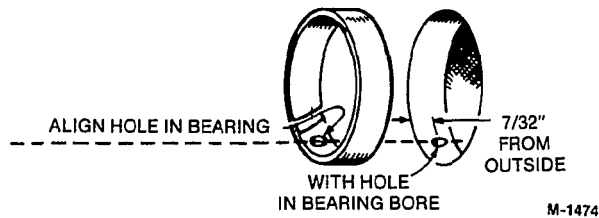

FIGURE 9-31. CAMSHAFT BEARINGS

### Crankshaft Bearings

Lubricate the bearings with light oil. Using the appropriate driver, start the bearings straight from the inner side of the block or rear bearing plate. The oil holes must line up so that they are at least half open. The notches in the front bearing flange must also line up with the lock pins in the block (Figure 9-32). Press the bearings in until the flange on the driver bottoms. The bearings are available in standard size and in 0.002, 0.010, 0.020 and 0.030 inch undersizes.

The front and rear crankshaft main bearings and thrust washers are separate parts in factory built engines. Replacement front bearings and thrust washers are one piece. Do not add a thrust washer to a replacement front bearing.

**NOTE:** DO NOT ADD ADDITIONAL THRUST WASHER WHEN REPLACING FRONT BEARING

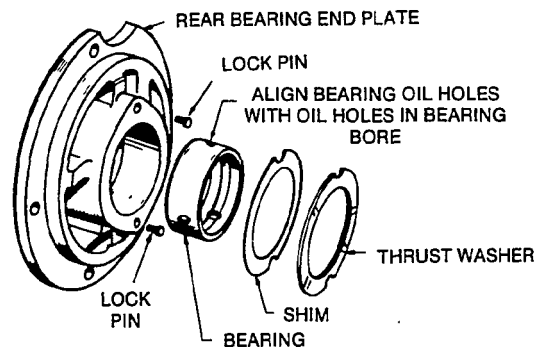
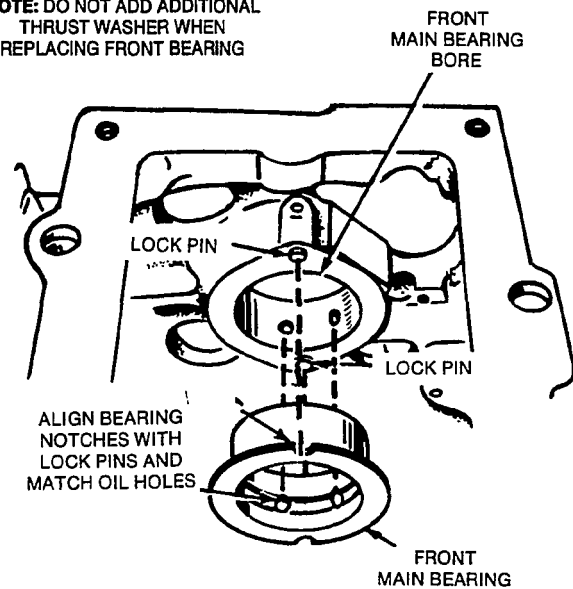
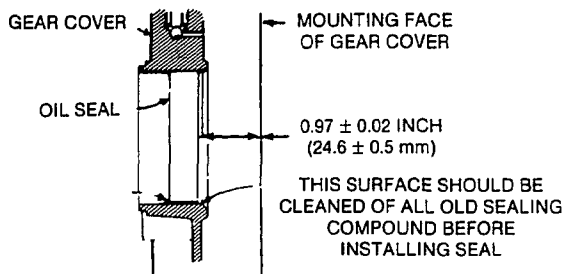

FIGURE 9-32. CRANKSHAFT BEARINGS

## OIL SEALS

The rear bearing plate and the gear cover must be removed to replace the crankshaft oil seals (Figure 9-33). Use an oil seal puller to pull out the old seals.

The new bearing must be installed in the rear bearing plate (see *Crankshaft Bearings* above) before the rear oil seal is installed. New oil seals must be installed with the appropriate oil seal drivers. The oil seal drivers include loaders that expand the oil seal lips to protect them from the sharp edges of the crankshaft keyways during assembly (see *Crankshaft* below). Lubricate the oil seal lips with oil or grease before inserting the loader.



GEAR COVER OIL SEAL

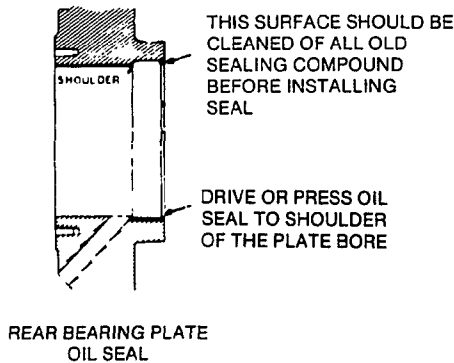

REAR BEARING PLATE OIL SEAL

M-1477

FIGURE 9-33. OIL SEALS

## CRANKSHAFT

1. Remove the rear bearing plate, gasket, shims and thrust washer. Rotate the crankshaft so that the crankthrow is aligned with the notch in the block and carefully lift out the crankshaft.
2. Clean the crankshaft thoroughly and inspect the journals for scoring, cracks and signs of overheating. Clean out the drilled oil passages to ensure lubrication of the connecting rod journals.

3. Measure the main and connecting rod journals at several places to check for out-of-roundness and taper.
4. Replace the crankshaft if it cannot be reconditioned by regrinding the journals. Main and connecting rod bearings are available in several undersizes.
5. Oil the front main bearing and carefully install the crankshaft through the rear opening in the block.
6. Oil the rear bearing and make sure the oil seal loader is in place (see *Oil Seals* above). Use oil to make the shim(s) and thrust washer adhere to the rear bearing plate. The flat side of the thrust washer should face the bearing plate and the shim(s) should be between the washer and the bearing plate.
7. Install the rear bearing plate and gasket. Make sure the gasket does not cover the oil holes in the back of the block and that the thrust washer does not slip out of place. Torque the bearing plate mounting nuts or bolts to specifications. The crankshaft should turn freely.
8. Check the crankshaft end play with a feeler gauge as shown in Figure 9-34. Be sure to push the front of the crankshaft to the rear to take up the endplay before making the measurement. If necessary, add or remove shims between the thrust washer and the rear bearing plate to obtain the specified crankshaft endplay.

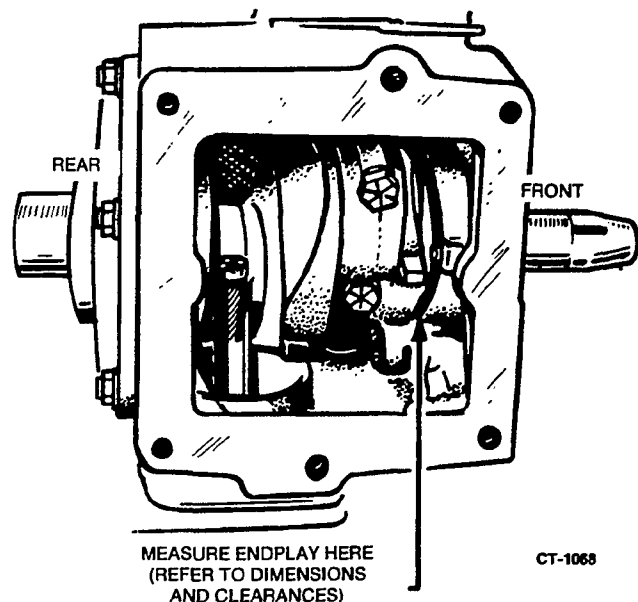

FIGURE 9-34. MEASURING CRANKSHAFT ENDPLAY

# Section 10. Service Checklist

---

Inspect and test the installation after servicing the set to confirm that it will operate as intended. Check each of the areas described below before putting the set into service.

## MOUNTING

Examine all mounting bolts and supporting members. All fasteners should be tightened securely to prevent vibration loosening.

## LUBRICATION

Fill the crankcase with oil of the recommended classification and viscosity grade. Fix any leaks immediately.

## COOLING

Fill the cooling system with the recommended coolant mixture unless cooled directly with sea water. Prime the sea water pump. Refer to the Operator's Manual. Fix any leaks immediately.

## WIRING

Check and tighten all load, control, grounding and battery connections.

## START-UP ADJUSTMENTS

Adjust the choke, carburetor and speed (frequency) in accordance with the procedures outlined in *Fuel System*.

## EXHAUST SYSTEM

Inspect the entire exhaust system, including the exhaust manifold, muffler, and exhaust hose. Look and listen for leaks at all fittings and joints while the set is running. Fix any leaks immediately.

## FUEL SYSTEM

Inspect the fuel supply lines, filters, and fittings for leaks while the set is running. Check flexible fuel lines for cuts, cracks, abrasions and rubbing that could cause abrasions.

**▲WARNING** *Leaking fuel will create a fire or explosion hazard that can result in severe personal injury or death if ignited. If any leaks are detected, shut the generator set down and have any leaks repaired immediately.*

## CONTROL

Check the set and remote control panels by starting and stopping the set several times from each location.

## MECHANICAL

Stop the generator set and inspect it for leaking gaskets, loose fasteners, damaged components, or interference with other equipment. Repair as required.

## ▲WARNING

### EXHAUST GAS IS DEADLY!

*Exhaust gases contain carbon monoxide, an odorless and colorless gas formed during the combustion of hydrocarbon fuels. Carbon monoxide is poisonous and can cause unconsciousness and death. Symptoms of carbon monoxide poisoning are the following:*

- *Inability to Think Coherently*
- *Vomiting*
- *Muscular Twitching*
- *Throbbing in Temples*
- *Dizziness*
- *Headache*
- *Weakness and Sleepiness*

*If you or anyone else experience any of these symptoms, shut down the unit and get out into the fresh air immediately. If symptoms persist, seek medical attention. DO NOT OPERATE THE UNIT UNTIL IT HAS BEEN INSPECTED AND REPAIRED.*

*The best protection against carbon monoxide inhalation is proper installation and regular, frequent visual and audible inspections of the complete exhaust system.*







Cummins Power Generation  
1400 73rd Avenue N.E.  
Minneapolis, MN 55432  
763-574-5000  
Fax: 763-574-8087

Cummins and Onan are registered trademarks of Cummins Inc.